

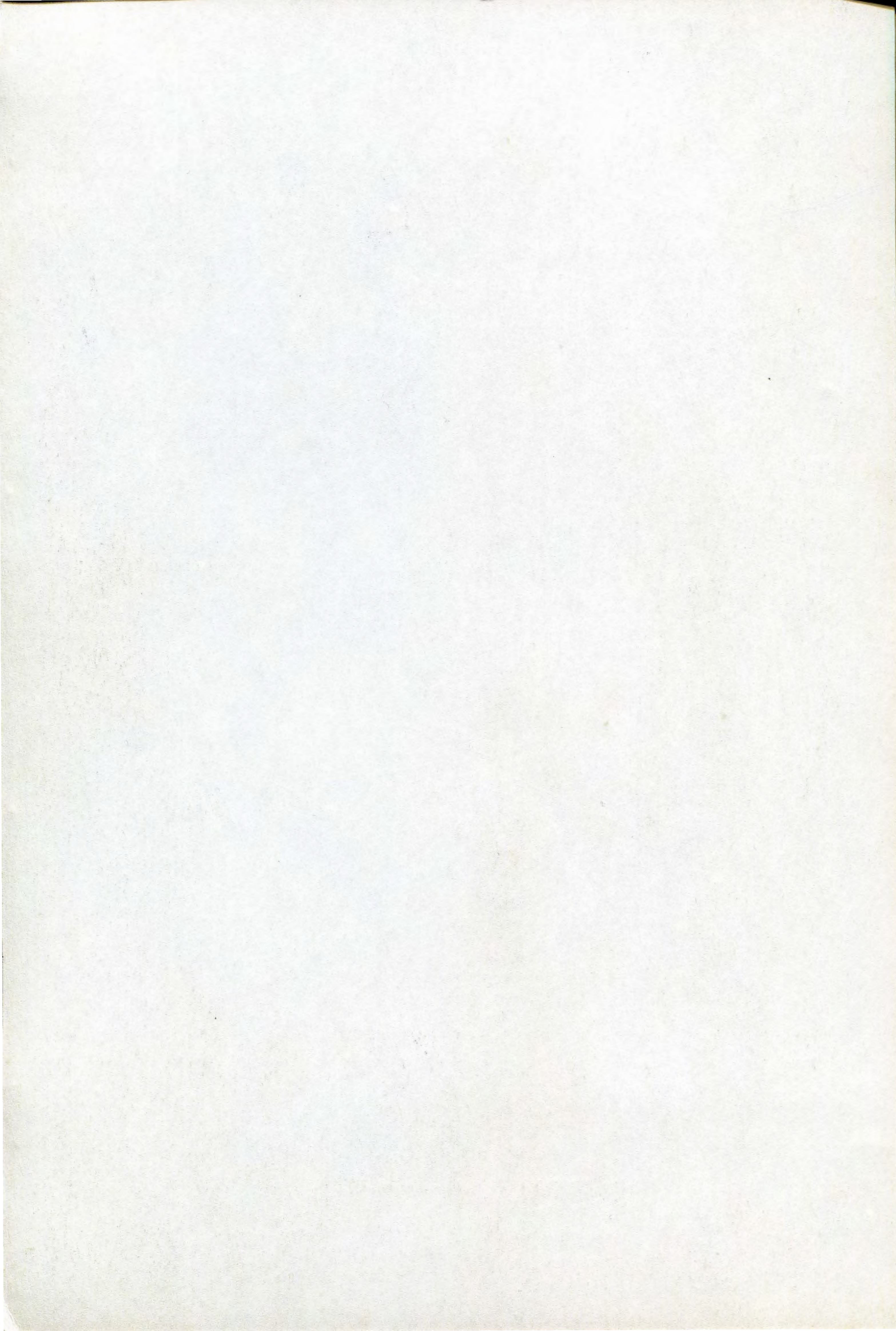

CHROM-VANADIUM

PREISLISTE 1961 P



Hazel Assistant

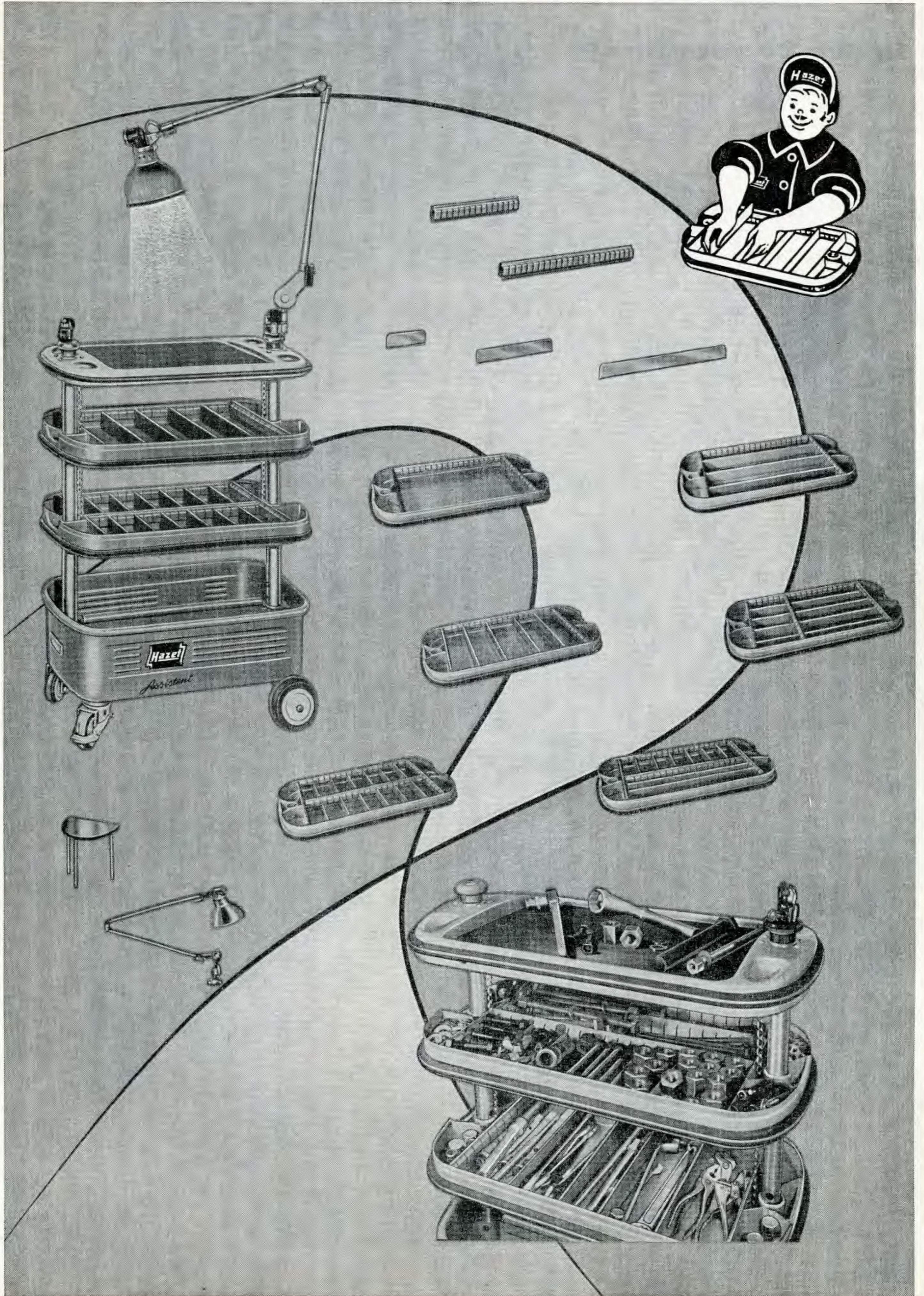

Hazel

Assistent

in der Verwendung

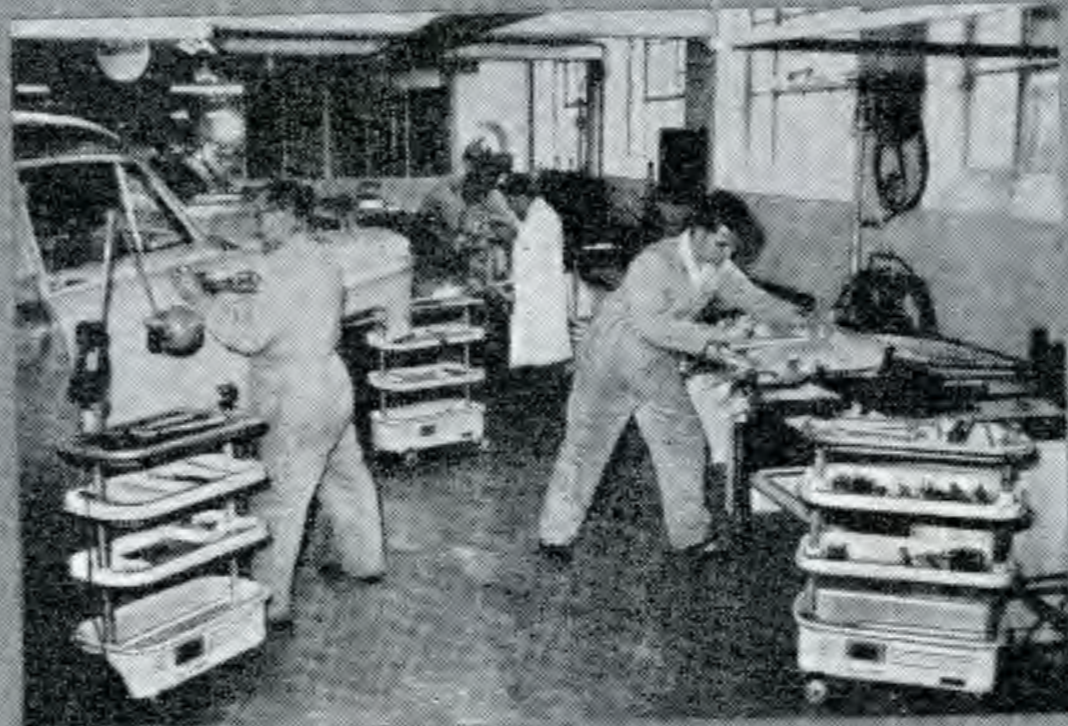
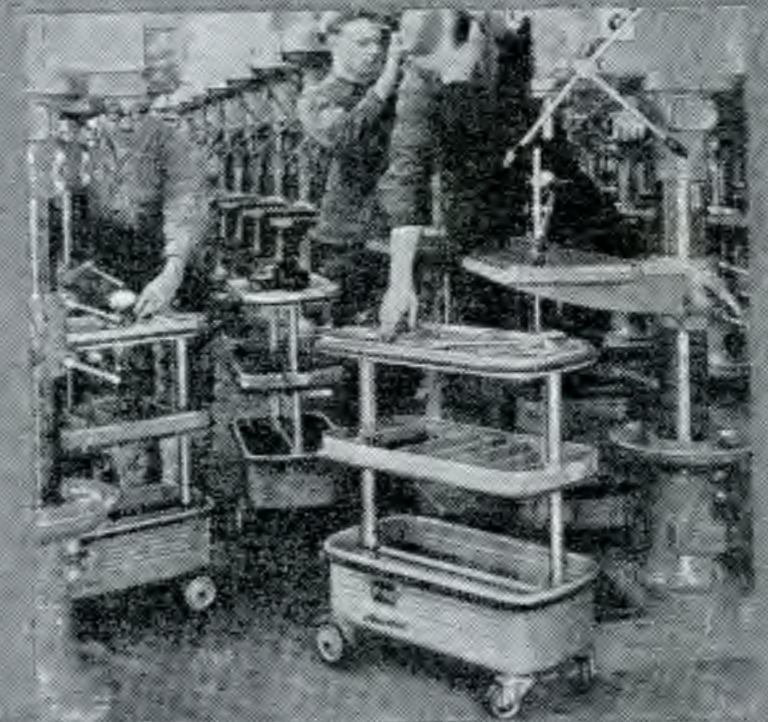
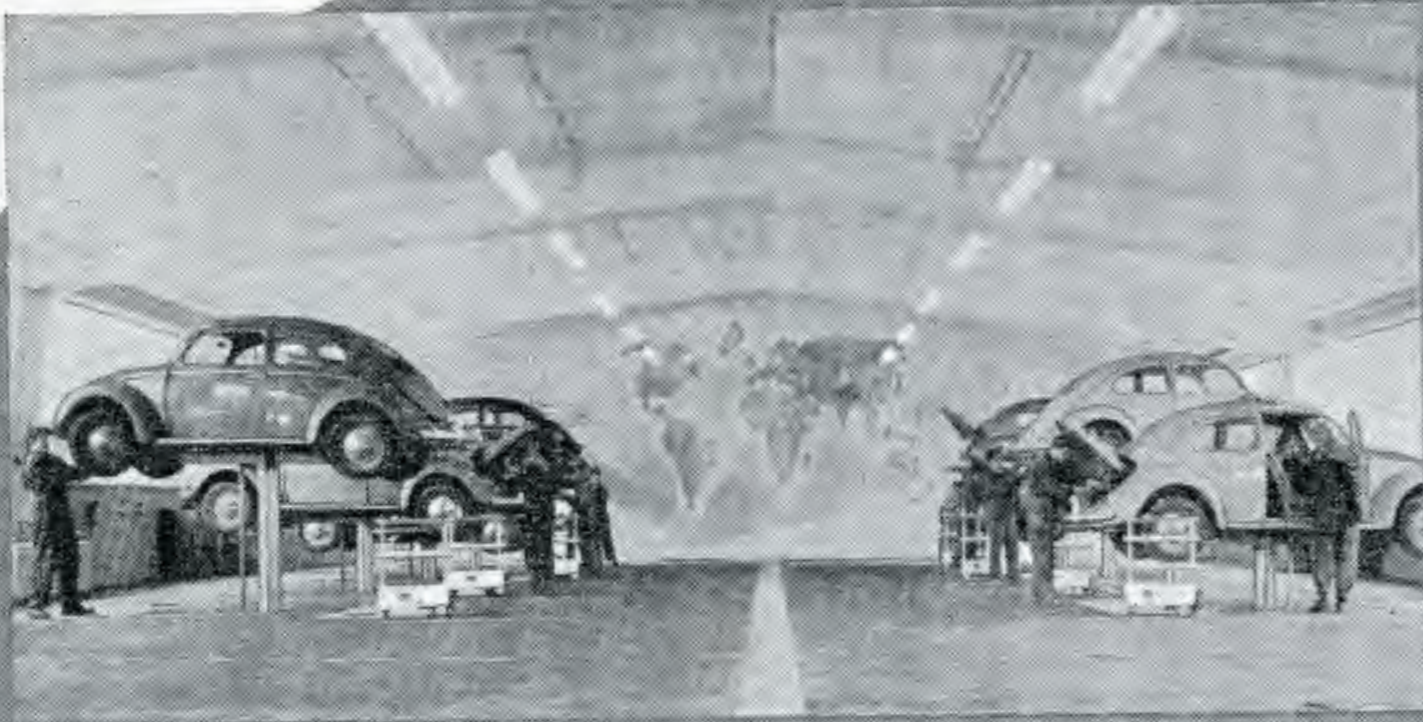
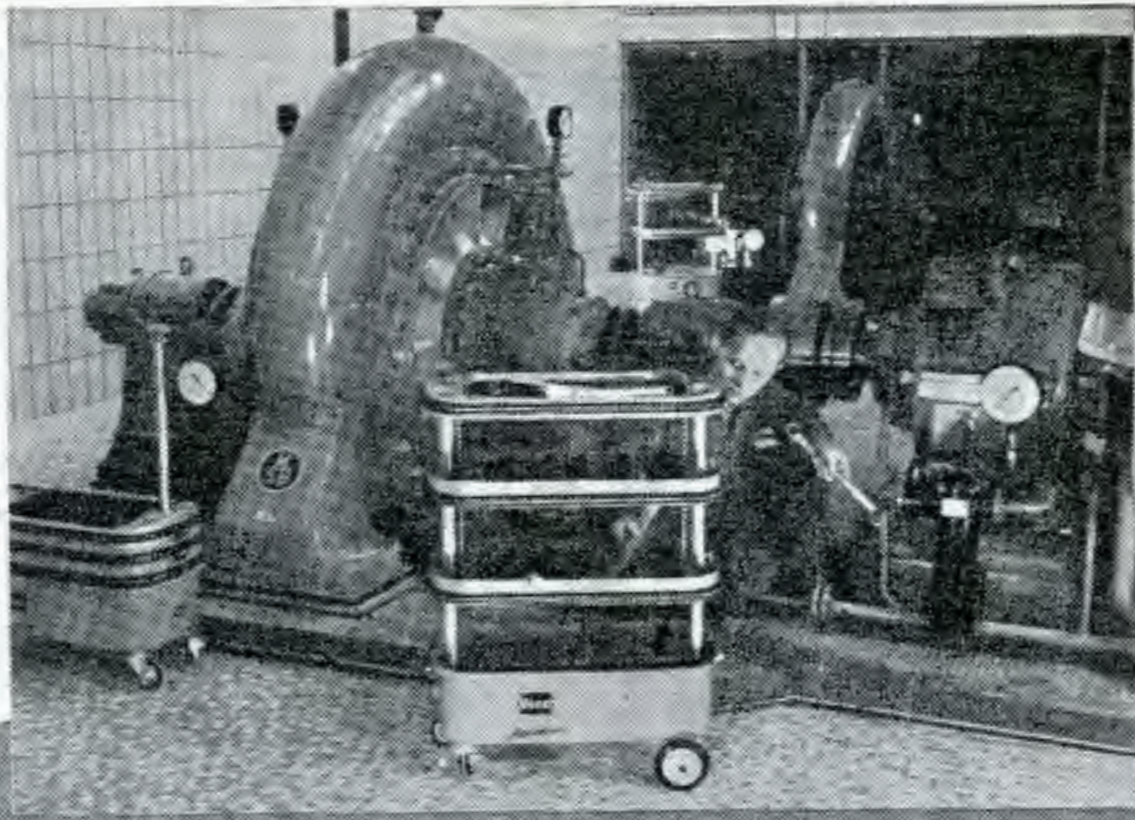



Großer Werkzeugschrank

100*

zweitürig, aus Stahlblech, Schubfächer auf Teleskop-schienen laufend

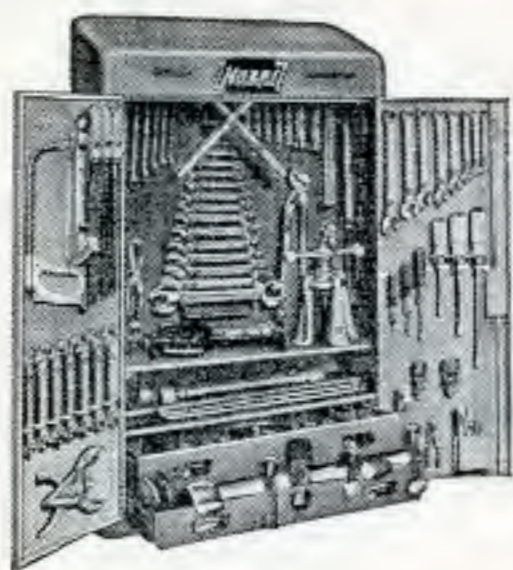

Bestell-Nr.	Inhalt	Verchromt
100	140 teilig	1228.—
100 A	135 teilig	1182.—
100 W	122 teilig	1200.—
100 AWM	123 teilig	954.—
101	143 teilig	1374.—
101 A	138 teilig	1328.—
101 W	125 teilig	1346.—
100 L	leer	354.—



Kleiner Werkzeugschrank

110*

zweitürig, aus Stahlblech

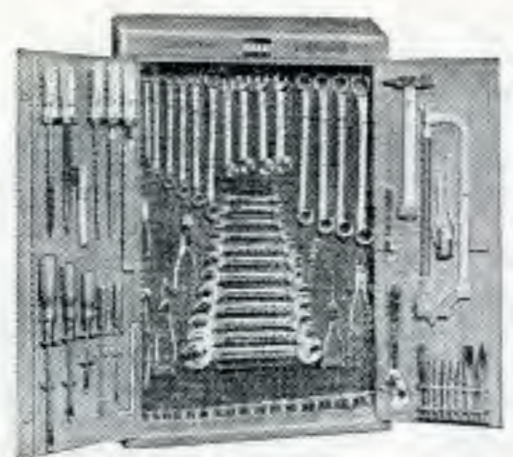

110	95 teilig	580.—
110 A	90 teilig	566.—
110 W	78 teilig	555.—
110 L	leer	166.—



Werkbank mit Aufsatzschrank

130

Werkbank mit 2 Untersätzen auf verstellbaren Füßen

Aufsatzschrank mit Aluminiumrolläden

Sämtliche Werkzeugplätze farbig schabloniert



130	107 teilig	2232.—
130 AW	113 teilig	2244.—
130 MS	107 teilig	1374.—
130 AWS	113 teilig	1386.—
130/1	122 teilig	2470.—
130/1 AW	128 teilig	2486.—
130/1 MS	122 teilig	1612.—
130/1 AWS	128 teilig	1628.—
130 L	Werkbank, leer	858.—
130 SL	Schrank, leer	800.—



Werkzeugkoffer „Juwel“

150

Schubfächer auf Teleskop-schienen laufend



Bestell-Nr.	Inhalt	Verchromt
150	135 teilig	974.—
150 A	131 teilig	956.—
150 W	112 teilig	886.—
150 L	leer	230.—



Assistent*

Werkzeug-, Material- und Montagewagen

für den innerbetrieblichen rationellen Transport in allen Branchen

DBP-Nr. 949640 und Auslandspatente

161 mit einem Zwischenkasten

162 mit zwei Zwischenkästen



161 L	leer	234.—
162 L	leer	276.—

Spezial-Werkzeugsortimente*

komplett mit Werkzeugwagen

A. für Motorenschlosser

161	100 teilig	630.—
161/1	64 teilig	476.—
162	100 teilig	672.—
162/1	64 teilig	518.—
161 A	92 teilig	610.—
161/1 A	59 teilig	464.—
162 A	92 teilig	652.—
162/1 A	59 teilig	506.—
161 W	85 teilig	606.—
161/1 W	51 teilig	442.—
162 W	85 teilig	648.—
162/1 W	51 teilig	484.—



Assistent*

Bestell-Nr.	Inhalt	Verchromt
B. für Karoserieschlosser		
161/3	28 teilig	638.—
161/4	17 teilig	514.—
162/3	28 teilig	680.—
162/4	17 teilig	556.—

C. für Auto-Elektriker		
161/7	63 teilig	518.—
162/7	63 teilig	560.—
161/7 A	63 teilig	514.—
162/7 A	63 teilig	556.—
161/7 W	60 teilig	504.—
162/7 W	60 teilig	546.—

D. für Tankstellen		
161/9	60 teilig	532.—
162/9	60 teilig	574.—
161/9 A	58 teilig	530.—
162/9 A	58 teilig	572.—
161/9 W	56 teilig	518.—
162/9 W	56 teilig	560.—

E. für Landmaschinen-Reparatur		
161/11	74 teilig	664.—
162/11	74 teilig	706.—
161/11 A	74 teilig	658.—
162/11 A	74 teilig	700.—
161/11 W	69 teilig	662.—
162/11 W	69 teilig	704.—

F. für Industrie		
161/14	100 teilig	756.—
162/14	100 teilig	798.—
161/14 A	94 teilig	724.—
162/14 A	94 teilig	766.—
161/14 W	86 teilig	732.—
162/14 W	86 teilig	774.—



Assistent*

Einzelteile



Bestell-Nr.	Bezeichnung	Preis
1600	Zwischenkasten ohne Trennbleche, mit Aufhängeketten zur Erweiterung der Ausführung 161 auf 162 (Montageanleitung liegt dem Zwischenkasten bei)	38.80

Schlitzprofilschienen und Trennbleche für beliebige Unterteilungsmöglichkeiten der Zwischenkästen

1601	Schlitzprofilschiene 310 mm	5.20
1602	Schlitzprofilschiene 480 mm	5.80
1605	Trennblech 150 mm	0.50
1606	Trennblech 310 mm	0.80
1607	Trennblech 480 mm	1.20
1610	Hocker	17.60
1615	Leuchte	62.20

Hazel Verstellbare Schraubenschlüssel
179 SPEZIALSTAHL



Bestell-Nr.	mm	Zoll	Poliert
179 - 4	100	4	3.30
6	150	6	4.30
8	200	8	5.50
10	250	10	7.—
12	300	12	9.80
15	380	15	18.—
18	460	18	28.80

Hazel Verstellbare Schraubenschlüssel
180 CHROM-VANADIUM



Bestell-Nr.	mm	Zoll	Verchromt Köpfe Hochglanz
180 - 4	100	4	6.—
6	150	6	7.20
8	200	8	9.—
10	250	10	12.20
12	300	12	16.60

Werbe- und Verkaufsständer

Bestell-Nr.	Inhalt	Preis
R 179	4, 6, 8, 10, 12" 2 2 2 2 1 St.	50.—
R 180	wie vor	85.40
V 179	4, 6, 8, 10, 12" 2 3 3 2 2 St. zusätzlich je 1 Paar Backen, Rollen, Stifte und Federn in Tasche	100.—
V 180	wie vor	155.80

Hazel **300**



300 vorerst nicht lieferbar

Hazel Ventil-Einstellschlüssel
320 CHROM-VANADIUM
Maulstellung 0° und 22 1/2°



Metr. Maße Gleiche Schlüsselweiten

Bestell-Nr.	mm	Verchromt Köpfe geschliffen
320 - 08	8 x 8	4.—
09	9 x 9	
10	10 x 10	
11	11 x 11	4.20
12	12 x 12	
13	13 x 13	
14	14 x 14	4.30
15	15 x 15	
16	16 x 16	
17	17 x 17	4.60
18	18 x 18	
19	19 x 19	
20	20 x 20	4.90
21	21 x 21	
22	22 x 22	

Hazel Ventil-Einstellschlüssel
320 CHROM-VANADIUM



Amerik. Maße

Bestell-Nr.	Zoll	Verchromt Köpfe geschliffen
320 A - 10	5/16 x 5/16	4.—
12	3/8 x 3/8	4.20
14	7/16 x 7/16	
16	1/2 x 1/2	4.30
18	9/16 x 9/16	
19	19/32 x 19/32	
20	5/8 x 5/8	4.60
22	11/16 x 11/16	
24	3/4 x 3/4	4.90
25	25/32 x 25/32	
28	7/8 x 7/8	

Sätze in hausfarbenen HAZET-Schachteln
Metr. Maße

Bestell-Nr.	Inhalt	Verchr. Köpfe geschliffen
320/7	12 x 12 13 x 13 14 x 14 15 x 15 16 x 16 17 x 17 18 x 18	30.90
320/15	8 x 8 9 x 9 10 x 10 11 x 11 12 x 12 13 x 13 14 x 14 15 x 15 16 x 16 17 x 17 18 x 18 19 x 19 20 x 20 21 x 21 22 x 22	66.70

Amerik. Maße

320/7 A	7/16 — 7/8	31.80
---------	------------	-------

Hazel **320**



Metr. Maße Ungleiche Schlüsselweiten

Bestell-Nr.	mm/Zoll	Verchromt Köpfe geschliffen
320 - 0089	8 x 9	4.—
1011	10 x 11	4.20
1213	12 x 13	
1415	14 x 15	4.30
1617	16 x 17	4.60
1819	18 x 19	
2022	20 x 22	4.90

Amerik. Maße

320 A - 0810	1/4 x 5/16	4.—
1214	3/8 x 7/16	4.20
1416	7/16 x 1/2	
1618	1/2 x 9/16	4.30
2022	5/8 x 11/16	4.60
2428	3/4 x 7/8	4.90

Engl. Maße

320 W - 0068	3/16 x 1/4	4.20
0810	1/4 x 5/16	4.30
1012	5/16 x 3/8	4.60
1214	3/8 x 7/16	4.90

Sätze in hausfarbenen HAZET-Schachteln
Metr. Maße

Bestell-Nr.	Inhalt	Verchr. Köpfe geschliffen
320/7 U	8 x 9 10 x 11 12 x 13 14 x 15 16 x 17 18 x 19 20 x 22	30.60

Amerik. Maße

320/6 AU	1/4 — 7/8	26.—
----------	-----------	------

Engl. Maße

320/4 WU	3/16 — 7/16	18.—
----------	-------------	------

Hazel Ventil-Einstellschlüssel
325 CHROM-VANADIUM
kurze Form
Maulstellung 0° und 30°



Bestell-Nr.	mm	Verchromt
325	14 x 14	3.90

Hazel Geißfuß-Schlüssel
326 CHROM-VANADIUM
für Ventileinstellung



326 vorerst nicht lieferbar

Hazel Spezialwerkzeug
327 CHROM-VANADIUM
für Ventileinstellung, DBGM
mit Schraubenzieher



327	14	31.40
327 - 1	loser Schlüssel	23.40
327 - 2	loser Schraubenzieher	8.—

Hazel Spezialwerkzeug
328 CHROM-VANADIUM
für Ventileinstellung, DBGM
mit Schraubenzieher

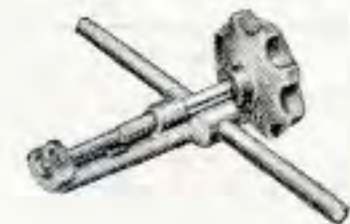

328	14	27.60
328 - 1	loser Schlüssel	20.70
328 - 2	loser Schraubenzieher	6.90

Hazel Kleingabelschlüssel
330 CHROM-VANADIUM
Maulstellung 15° und 60°



Metr. Maße

Bestell-Nr.	mm		Verchromt Köpfe geschliffen
	15°	60°	
330 - 0354	3,5	4	2.20
0435	4	3,5	
0455	4,5	5	
0545	5	4,5	
0556	5,5	6	
0655	6	5,5	
0078	7	8	2.50
0087	8	7	
0910	9	10	2.50
1009	10	9	
1112	11	12	2.70
1211	12	11	
1314	13	14	2.90
1413	14	13	



**Kleingabelschlüssel
CHROM-VANADIUM**

330



Amerik. Maße

Bestell-Nr.	Zoll		Verchromt Köpfe geschliffen
	15°	60°	
330 A - 1213	3/16	13/64	2.20
1312	13/64	3/16	
1315	13/64	15/64	
1513	15/64	13/64	
1415	7/32	15/64	
1514	15/64	7/32	2.50
1416	7/32	1/4	
1614	1/4	7/32	
1618	1/4	9/32	
1816	9/32	1/4	
1820	9/32	5/16	2.50
2018	5/16	9/32	
1719	17/64	19/64	
1917	19/64	17/64	
2022	5/16	11/32	
2220	11/32	5/16	
2224	11/32	3/8	
2422	3/8	11/32	
2428	3/8	7/16	2.70
2824	7/16	3/8	
2832	7/16	1/2	

Engl. Maße

Bestell-Nr.	9 BA	8 BA	2.20
330 BA - 98	8 BA	9 BA	
89	7 BA	6 BA	
76	6 BA	7 BA	2.50
67	5 BA	4 BA	
54	4 BA	5 BA	
45	3 BA	2 BA	
32	2 BA	3 BA	
23	1 BA	0 BA	2.50
10	0 BA	1 BA	

**Sätze in hausfarbenen HAZET-Schachteln
oder Plastic-Taschen (P)**

Metr. Maße

Bestell-Nr.	Inhalt		Verchr. Köpfe geschliffen
330/14	3,5 x 4 4,5 x 5 5,5 x 6 7 x 8 9 x 10 11 x 12 13 x 14	4 x 3,5 5 x 4,5 6 x 5,5 8 x 7 10 x 9 12 x 11 14 x 13	34.40
330/14 P	wie vor, jedoch in Plastic-Tasche		

Amerik. Maße

Bestell-Nr.	Inhalt	Verchromt Köpfe geschliffen
330/6 A	7/32 — 11/32	14.40
330/6 AP	7/32 — 11/32	17.60
330/9 A	13/64 — 1/2	21.50
330/9 AP	13/64 — 1/2	24.60
330/10 A	7/32 — 7/16	24.80
330/10 AP	7/32 — 7/16	28.20
331/11 AP	9/330/13/64-1/2 1/760/4 1/2 1/832-1	31.80

Engl. Maße

Bestell-Nr.	Inhalt	Verchromt Köpfe geschliffen
330/8 BA	7 BA — 0 BA	18.80
330/8 BAP	7 BA — 0 BA	22.—



**Steckschlüssel
CHROM-VANADIUM**

430

aus dem Vollen geschmiedet
und ausgebohrt



Bestell-Nr.	mm	Verchromt Köpfe geschliffen
430 - 0067	6 x 7	3.70
0089	8 x 9	
0810	8 x 10	4.—
0910	9 x 10	
0911	9 x 11	4.10
1011	10 x 11	
1114	11 x 14	4.50
1213	12 x 13	
1214	12 x 14	
1315	13 x 15	5.30
1415	14 x 15	
1417	14 x 17	6.10
1617	16 x 17	
1719	17 x 19	7.40
1819	18 x 19	
1922	19 x 22	8.40
2022	20 x 22	
2123	21 x 23	8.80
2224	22 x 24	
2426	24 x 26	9.90
2427	24 x 27	
2528	25 x 28	11.—
2729	27 x 29	11.40
2730	27 x 30	
2732	27 x 32	14.40
3032	30 x 32	
3236	32 x 36	21.30



430

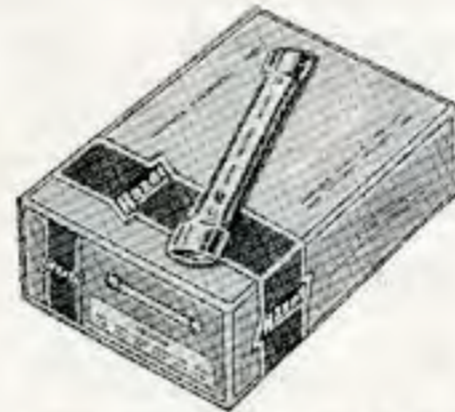

Sätze in hausfarbenen HAZET-Schachteln

Bestell-Nr.	Inhalt		Verchromt Köpfe geschliffen
430/7	8 x 9 12 x 13 16 x 17 20 x 22	10 x 11 14 x 15 18 x 19	39.50
430/8	6 x 7 10 x 11 14 x 15 18 x 19	8 x 9 12 x 13 16 x 17 20 x 22	
430/12	8 x 9 12 x 13 16 x 17 20 x 22 24 x 26 27 x 29	10 x 11 14 x 15 18 x 19 21 x 23 25 x 28 30 x 32	95.—



**Steckschlüssel
CHROM-VANADIUM**

430



Satz im hausfarbenen HAZET-Metallkasten

Bestell-Nr.	Inhalt	Verchromt Köpfe geschliffen
430/12K	8 x 9 10 x 11 12 x 13 14 x 15 16 x 17 18 x 19 20 x 22 21 x 23 24 x 26 25 x 28 27 x 29 30 x 32 Drehstifte	124.—



430

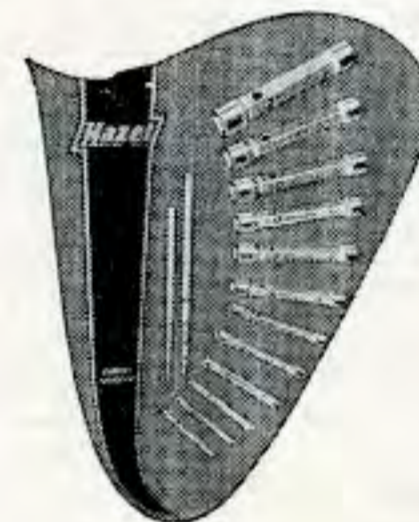

Sätze auf Dekorations- und Verkaufstafeln

Bestell-Nr.	Sortimente	Verchromt Köpfe geschliffen
D 430/14	8 x 9—30 x 32 Drehstifte	102.90
DV 430/43	8 x 9—30 x 32 Drehstifte	285.70



433

**Drehstifte
CHROM-VANADIUM
stufenförmig**



Bestell-Nr.	für Schlüssel	Verchromt
433 - 0619	6 — 19	3.70
2032	20 — 32	4.20
3236	32 — 36	5.30





Gabelschlüssel
CHROM-VANADIUM
lange schlanke Form

450



Metr. Maße

Bestell-Nr.	mm	Verchromt
450 - 0045	4 x 5	1.40
0056	5 x 6	
0067	6 x 7	
0068	6 x 8	
0078	7 x 8	
0079	7 x 9	1.70
0089	8 x 9	
0810	8 x 10	
0910	9 x 10	
0911	9 x 11	1.80
1011	10 x 11	
1012	10 x 12	
1112	11 x 12	
1014	10 x 14	
1113	11 x 13	2.—
1114	11 x 14	
1213	12 x 13	
1214	12 x 14	
1315	13 x 15	
1415	14 x 15	2.20
1416	14 x 16	
1516	15 x 16	
1417	14 x 17	
1617	16 x 17	2.50
1618	16 x 18	
1719	17 x 19	
1819	18 x 19	2.60
1820	18 x 20	
1722	17 x 22	
1922	19 x 22	2.70
2022	20 x 22	
1924	19 x 24	
2123	21 x 23	2.90
2224	22 x 24	
2227	22 x 27	
2426	24 x 26	3.60
2427	24 x 27	
2430	24 x 30	
2527	25 x 27	
2528	25 x 28	3.80
2628	26 x 28	
2629	26 x 29	
2729	27 x 29	
2730	27 x 30	4.50
2732	27 x 32	
2830	28 x 30	
3032	30 x 32	
3036	30 x 36	
3235	32 x 35	7.40
3236	32 x 36	
3641	36 x 41	12.50
3842	38 x 42	
4146	41 x 46	18.50
4650	46 x 50	24.—



Gabelschlüssel
CHROM-VANADIUM

450



Amerik. Maße

Bestell-Nr.	Zoll	Verchromt
450 A - 0810	1/4 x 5/16	1.40
1012	5/16 x 3/8	1.70
1013	5/16 x 13/32	
1214	3/8 x 7/16	1.80
1416	7/16 x 1/2	2.—
1618	1/2 x 9/16	
1619	1/2 x 19/32	2.20
1820	9/16 x 5/8	
1822	9/16 x 11/16	2.50
1922	19/32 x 11/16	
2022	5/8 x 11/16	
2024	5/8 x 3/4	
2025	5/8 x 25/32	2.60
2224	11/16 x 3/4	
2225	11/16 x 25/32	
2226	11/16 x 13/16	
2425	3/4 x 25/32	
2228	11/16 x 7/8	
2428	3/4 x 7/8	
2526	25/32 x 13/16	
2528	25/32 x 7/8	
2628	13/16 x 7/8	
2830	7/8 x 15/16	2.90
2831	7/8 x 31/32	
2834	7/8 x 1 1/16	3.60
3032	15/16 x 1	
3236	1 x 1 1/8	3.80
3436	1 1/16 x 1 1/8	
3440	1 1/16 x 1 1/4	4.50
3842	1 3/16 x 1 5/16	
4044	1 1/4 x 1 3/8	7.40
4046	1 1/4 x 1 7/16	
4248	1 5/16 x 1 1/2	
4448	1 3/8 x 1 1/2	
4652	1 7/16 x 1 5/8	12.50
5258	1 5/8 x 1 13/16	18.50
5460	1 11/16 x 1 7/8	
5864	1 13/16 x 2	24.—
5666	1 3/4 x 2 1/16	
Engl. Maße		
450 W - 0023	1/16 x 3/32	1.40
0034	3/32 x 1/8	1.70
0046	1/8 x 3/16	1.80
0068	3/16 x 1/4	2.—
0810	1/4 x 5/16	2.20
1012	5/16 x 3/8	2.50
1214	3/8 x 7/16	2.70
1416	7/16 x 1/2	2.90
1618	1/2 x 9/16	3.60
1620	1/2 x 5/8	
1820	9/16 x 5/8	3.80
1822	9/16 x 11/16	
2024	5/8 x 3/4	4.50
2224	11/16 x 3/4	
2226	11/16 x 13/16	7.40
2428	3/4 x 7/8	
2832	7/8 x 1	12.50
3236	1 x 1 1/8	18.50
3640	1 1/8 x 1 1/4	24.—



Gabelschlüssel
CHROM-VANADIUM

450

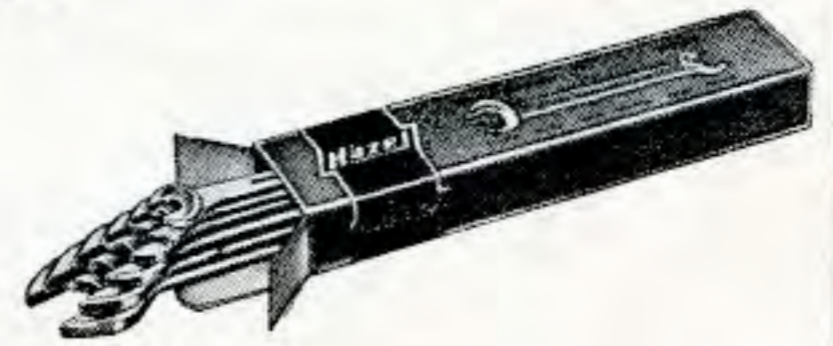

Sätze in hausfarbenen HAZET-Schachteln
Metr. Maße

Bestell-Nr.	Inhalt	Verchr.
450/6	8 x 9 10 x 11 12 x 13 14 x 15 16 x 17 18 x 19	12.80
450/7	6 x 7 8 x 9 10 x 11 12 x 13 14 x 15 16 x 17 18 x 19	14.20
450/7 I	8 x 9 10 x 11 12 x 13 14 x 15 16 x 17 18 x 19 20 x 22	15.50
450/8	6 x 7 8 x 9 10 x 11 12 x 13 14 x 15 16 x 17 18 x 19 20 x 22	16.90
450/9	8 x 9 10 x 11 12 x 13 14 x 15 16 x 17 18 x 19 20 x 22 24 x 27 30 x 32	23.60
450/10	6 x 7 8 x 9 10 x 11 12 x 13 14 x 15 16 x 17 18 x 19 20 x 22 24 x 26 27 x 32	25.—
450/11	6 x 7 8 x 9 10 x 11 12 x 13 14 x 15 16 x 17 18 x 19 20 x 22 24 x 27 25 x 28 30 x 32	28.80
450/12	6 x 7 8 x 9 10 x 11 12 x 13 14 x 15 16 x 17 18 x 19 20 x 22 21 x 23 24 x 26 25 x 28 27 x 32	31.70
450/12 I	6 x 7 8 x 9 10 x 11 12 x 13 14 x 15 16 x 17 18 x 19 20 x 22 21 x 23 24 x 26 27 x 29 30 x 32	32.40
450/12 II	6 x 7 8 x 9 10 x 11 12 x 13 14 x 15 16 x 17 18 x 19 20 x 22 21 x 23 24 x 26 25 x 27 30 x 32	31.70
450/13	6 x 7 8 x 9 10 x 11 12 x 13 14 x 15 16 x 17 18 x 19 20 x 22 21 x 23 24 x 26 25 x 28 27 x 32 36 x 41	44.20
Amerik. Maße		
450/5 A	1/4 — 3/4	10.30
450/6 A I	5/16 — 7/8	13.30
450/6 A III	3/8 — 1	15.20
450/7 A	5/16 — 1 1/8	18.60
450/8 A	1/4 — 1	18.30
450/9 A	1/4 — 1 1/4	24.20
450/10 A	1/4 — 1	22.90
450/12 A	1/4 — 1 1/4	31.70
Engl. Maße		
450/5 W	1/8 — 5/8	13.20
450/6 W	1/8 — 1/2	14.10
450/7 W	1/16 — 1	28.70
450/9 W	1/8 — 3/4	26.—
450/10 W	1/8 — 13/16	33.40
450/12 W	1/8 — 1	53.30



**Gabelschlüssel
CHROM-VANADIUM**

450

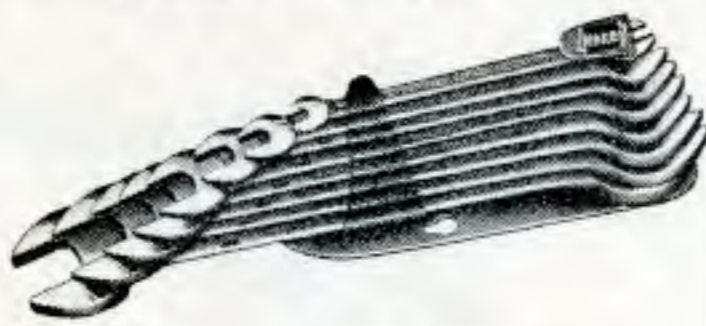

im „Remscheid“-Halter

Metr. Maße

Bestell-Nr.	Inhalt	Verchr.
450/8 Rd	6 x 7 8 x 9 10 x 11 12 x 13 14 x 15 16 x 17 18 x 19 20 x 22	19.70
450/10 Rd	6 x 7 8 x 9 10 x 11 12 x 13 14 x 15 16 x 17 18 x 19 20 x 22 24 x 26 27 x 32	29.—
450/12 Rd	6 x 7 8 x 9 10 x 11 12 x 13 14 x 15 16 x 17 18 x 19 20 x 22 21 x 23 24 x 26 25 x 28 27 x 32	36.30

Amerik. Maße

450/6 A I Rd	5/16 — 7/8	15.80
450/6 A III Rd	3/8 — 1	17.70
450/7 A Rd	5/16 — 1 1/8	21.30
450/8 A Rd	1/4 — 1	21.10

Engl. Maße

450/6 W Rd	1/8 — 1/2	16.60
450/8 W Rd	1/16 — 1/2	20.—



450



Sätze auf Dekorations- und Verkaufstafeln

Metr. Maße

D 450/12	6 x 7 — 27 x 32	31.70
DV 450/39	6 x 7 — 27 x 32	94.80

Amerik. Maße

D 450/12 A	1/4 — 1 1/4	31.70
DV 450/39 A	1/4 — 1 1/4	94.80

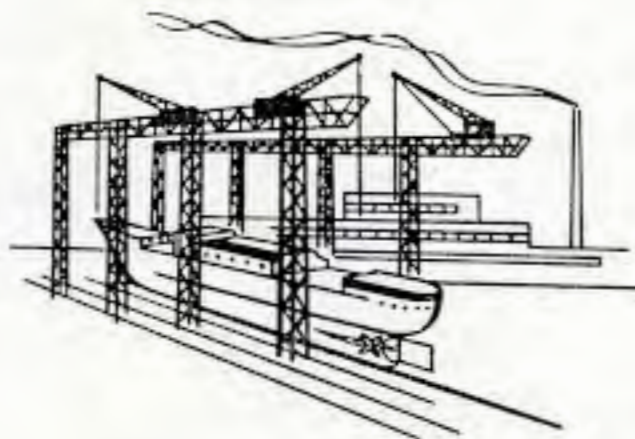

**Gabel-Ringschlüssel
CHROM-VANADIUM**

600

lange Form, schlank und dünnwandig, Ringschlüsselkopf 15° abgebogen



Metr. Maße

Gleiche Schlüsselweiten

Bestell-Nr.	mm/Zoll	Verchromt Köpfe Hochglanz
600-06	6	2.30
07	7	
08	8	2.50
09	9	2.60
10	10	2.70
11	11	2.90
12	12	3.10
13	13	3.30
14	14	3.60
15	15	3.90
16	16	4.10
17	17	4.40
18	18	4.70
19	19	5.10
20	20	5.50
21	21	
22	22	6.50
23	23	
24	24	7.10
25	25	
26	26	8.20
27	27	
28	28	9.70
30	30	
32	32	11.20
36	36	13.10
41	41	16.—

Amerik. Maße

600 A - 08	1/4	2.30
10	5/16	2.50
12	3/8	2.70
14	7/16	2.90
16	1/2	3.30
18	9/16	3.60
20	5/8	4.10
22	11/16	4.40
24	3/4	5.10
26	13/16	5.50
28	7/8	6.50
30	15/16	7.10
32	1	8.20
34	1 1/16	
36	1 1/8	9.70
40	1 1/4	
42	1 5/16	11.20
44	1 3/8	
46	1 7/16	13.10
48	1 1/2	
52	1 5/8	16.—



**Gabel-Ringschlüssel
CHROM-VANADIUM**

600



Engl. Maße

Bestell-Nr.	Zoll	Verchromt Köpfe Hochglanz
600W - 04	1/8	2.60
06	3/16	2.90
08	1/4	3.30
10	5/16	3.90
12	3/8	4.70
14	7/16	5.50
16	1/2	6.50
18	9/16	8.20
20	5/8	9.70
22	11/16	
24	3/4	11.20
26	13/16	
28	7/8	13.10
30	15/16	
32	1	16.—



600

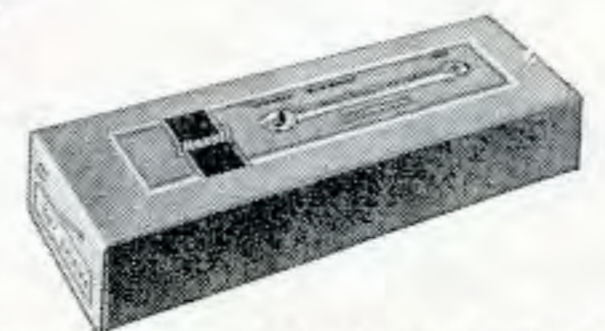

Sätze in hausfarbenen HAZET-Schachteln

Metr. Maße

Bestell-Nr.	Inhalt	Verchr. Köpfe Hochgl.
600/6	9 11 14 17 19 22	25.10
600/8	9 11 14 17 19 22 27 32	46.—
600/10	8 9 11 14 17 19 22 24 27 32	55.60
600/12	6 7 9 11 13 14 17 19 22 24 27 32	61.—
600/25	alle Schlüssel von 6 — 32	137.40
600/27	alle Schlüssel von 6 — 41	166.50

Amerik. Maße

600/6 A I	5/16 — 5/8	19.10
600/6 A II	7/16 — 7/8	25.50
600/8 A I	3/8 — 1	36.40
600/8 A II	7/16 — 7/8	35.30
600/10 A	1/4 — 1	41.20
600/12 A I	1/4 — 1 5/16	62.10
600/12 A II	5/16 — 1	55.90
600/15 A	5/16 — 1 1/4	86.50

Engl. Maße

600/6 W	3/16 — 5/8	31.80
600/7 W	1/8 — 1/2	29.40
600/10 W	1/8 — 3/4	58.50



600

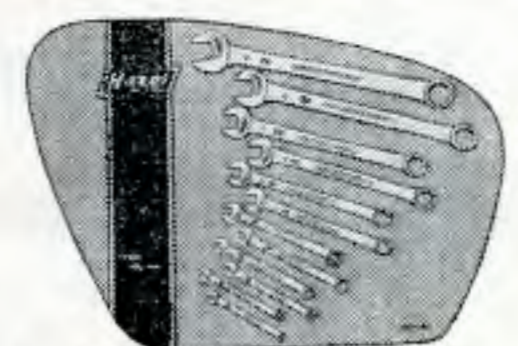

Sätze auf Dekorations- und Verkaufstafeln

Metr. Maße

D 600/12	6 — 32	61.—
DV 600/39	6 — 32	172.—
Amerik. Maße		
D 600/12 A	1/4 — 1 5/16	62.10
DV 600/39 A	1/4 — 1 5/16	174.50



Gabel-Ringschlüssel
CHROM-VANADIUM

605

kurze Form, schlank und dünnwandig. Ringschlüsselkopf 15° abgebogen



Metr. Maße Gleiche Schlüsselweiten

Bestell-Nr.	mm/Zoll	Verchromt Köpfe Hochglanz
605-06	6	1.70
07	7	
08	8	1.90
09	9	
10	10	2.20
11	11	
12	12	2.40
13	13	
14	14	2.70
15	15	
16	16	3.10
17	17	
18	18	3.70
19	19	
20	20	4.20
21	21	
22	22	4.90

Amerik. Maße

605 A - 08	1/4	1.70
10	5/16	1.90
12	3/8	
14	7/16	2.20
16	1/2	2.40
18	9/16	2.70
20	5/8	3.10
22	11/16	
24	3/4	3.70
26	13/16	4.20
28	7/8	4.90

Engl. Maße

605 W - 02	1/16	1.70
04	1/8	1.90
11	1 BA	
00	0 BA	2.20
06	3/16	
08	1/4	2.40
10	5/16	2.70
12	3/8	3.70
14	7/16	4.20
16	1/2	4.90



Gabel-Ringschlüssel
CHROM-VANADIUM

605



Sätze in hausfarbenen HAZET-Schachteln

Metr. Maße

Bestell-Nr.	Inhalt	Verchromt Köpfe Hochglanz
605/6	9 11 14 17 19 22	18.50
605/8	6 7 8 9 10 11 12 13	16.40
605/12	6 7 8 9 10 11 12 13 14 17 19 22	30.80
605/17	6 7 8 9 10 11 12 13 14 15 16 17 18 19 20 21 22	48.70

Amerik. Maße

605/7 A	5/16 — 3/4	17.90
605/7 A I	1/4 — 5/8	15.90
605/8 A	3/8 — 7/8	24.—
605/11 A	1/4 — 7/8	31.80

Engl. Maße

605/6 W	3/16 — 1/2	20.10
605/7 W	1/8 — 3/8	17.—
605/10 W	1/16 — 1/2	27.80



Ringschlüssel
CHROM-VANADIUM

610

gerade



Metr. Maße

Bestell-Nr.	mm	Verchromt Köpfe geschliffen
610 - 0067	6 x 7	1.90
0089	8 x 9	2.—
0810	8 x 10	2.20
0911	9 x 11	2.50
1011	10 x 11	
1114	11 x 14	2.60
1213	12 x 13	
1214	12 x 14	
1315	13 x 15	3.—
1415	14 x 15	
1417	14 x 17	3.30
1617	16 x 17	3.50
1618	16 x 18	
1719	17 x 19	3.80
1819	18 x 19	4.—
1922	19 x 22	4.80
2022	20 x 22	
2123	21 x 23	5.40
2224	22 x 24	
2426	24 x 26	5.80
2227	22 x 27	6.20
2427	24 x 27	
2528	25 x 28	6.80
2730	27 x 30	8.10
2732	27 x 32	
3032	30 x 32	
3036	30 x 36	9.20
3236	32 x 36	
3641	36 x 41	9.90



Ringschlüssel
CHROM-VANADIUM

610



Amerik. Maße

Bestell-Nr.	Zoll	Verchromt Köpfe geschliffen
610 A - 0810	1/4 x 5/16	1.90
1214	3/8 x 7/16	2.50
1416	7/16 x 1/2	2.60
1618	1/2 x 9/16	
1820	9/16 x 5/8	3.30
1922	19/32 x 11/16	3.50
2022	5/8 x 11/16	
2024	5/8 x 3/4	3.80
2425	3/4 x 25/32	4.—
2428	3/4 x 7/8	4.80
2526	25/32 x 13/16	
2628	13/16 x 7/8	
2830	7/8 x 15/16	5.40
3032	15/16 x 1	5.80
3236	1 x 1 1/8	6.80
3436	1 1/16 x 1 1/8	8.10
3440	1 1/16 x 1 1/4	
4046	1 1/4 x 1 7/16	9.20
4652	1 7/16 x 1 5/8	9.90

Engl. Maße

610 W - 0046	1/8 x 3/16	2.50
0068	3/16 x 1/4	2.60
0810	1/4 x 5/16	3.—
1012	5/16 x 3/8	3.30
1214	3/8 x 7/16	4.80
1416	7/16 x 1/2	5.40
1618	1/2 x 9/16	5.80
1820	9/16 x 5/8	6.80
2024	5/8 x 3/4	8.10
2428	3/4 x 7/8	9.20
2832	7/8 x 1	9.90



610

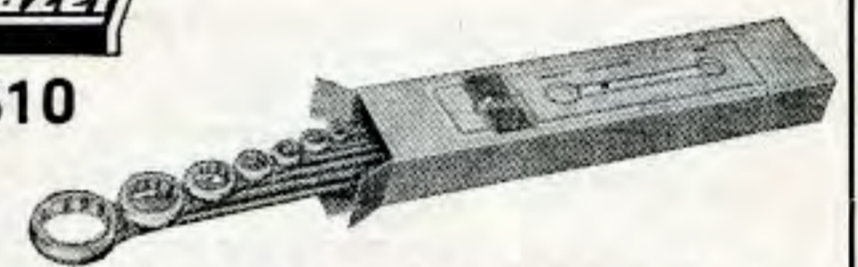

Sätze in hausfarbenen HAZET-Schachteln

Metr. Maße

Bestell-Nr.	Inhalt	Verchr. Köpfe geschliffen
610/6	8 x 9 10 x 11 12 x 13 14 x 15 16 x 17 18 x 19	17.60
610/8	6 x 7 8 x 9 10 x 11 12 x 13 14 x 15 16 x 17 18 x 19 20 x 22	24.30
610/10	6 x 7 8 x 9 10 x 11 12 x 13 14 x 15 16 x 17 18 x 19 20 x 22 24 x 26 27 x 32	38.20
610/12	6 x 7 8 x 9 10 x 11 12 x 13 14 x 15 16 x 17 18 x 19 20 x 22 21 x 23 24 x 26 25 x 28 27 x 32	50.40

Amerik. Maße

610/6 A	1/4 — 1	21.10
---------	---------	-------

Engl. Maße

610/6 W	1/8 — 1/2	21.60
---------	-----------	-------



**Ringschlüssel
CHROM-VANADIUM**

610



Sätze auf Dekorations- und Verkaufstafeln
Metr. Maße

Bestell-Nr.	Sortimente	Verchromt Köpfe geschliffen
D 610/12	6 × 7—27 × 32	50.40
DV 610/39	6 × 7—27 × 32	146.—
Amerik. Maße		
D 610/10 A	1/4—1 1/4	43.50
DV 610/31 A	1/4—1 1/4	120.30



**Starter-
und Blockschlüssel
CHROM-VANADIUM**

615



Metr. Maße

Bestell-Nr.	mm/Zoll	Verchromt Köpfe geschliffen
615 - 1113	11 × 13	4.60
1416	14 × 16	5.30
1417	14 × 17	
1517	15 × 17	
1922	19 × 22	7.10

Amerik. Maße

615 A - 1416	7/16 × 1/2	4.60
1820	9/16 × 5/8	5.30
2024	5/8 × 3/4	7.10
2428	3/4 × 7/8	

Engl. Maße

615W - 0068	3/16 × 1/4	4.60
0810	1/4 × 5/16	5.30
1214	3/8 × 7/16	7.10

Sätze in hausfarbenen HAZET-Schachteln
Metr. Maße

Bestell-Nr.	Inhalt	Verchromt Köpfe geschliffen
615/3	11 × 13 14 × 17 19 × 22	17.—

Amerik. Maße

615/3 A	7/16—3/4	17.—
----------------	----------	-------------



**Spezialschlüssel
CHROM-VANADIUM**

617*

für den Öldienst



für Kopfschrauben

Bestell-Nr.		Verchromt
617	7 Schlüsselweiten	8.50

618*



für Innenvierkant- und Schlitzschrauben

618	10 Schlüsselweiten	12.70
------------	--------------------	--------------



**Spezialschlüssel
CHROM-VANADIUM**

619*

für den Öldienst



für Opelwagen

Bestell-Nr.	mm	Verchromt
619 **	22 × 32 × 41	9.30



**Ringschlüssel
CHROM-VANADIUM**

625

lang, flach gekröpft,
Köpfe dünnwandig



Metr. Maße

Bestell-Nr.	mm/Zoll	Verchromt Köpfe geschliffen
625 - 0067	6 × 7	2.70
0089	8 × 9	3.—
0911	9 × 11	
1011	10 × 11	3.20
1114	11 × 14	3.50
1213	12 × 13	
1214	12 × 14	
1315	13 × 15	3.80
1415	14 × 15	
1417	14 × 17	4.—
1617	16 × 17	
1719	17 × 19	4.20
1819	18 × 19	4.40
1922	19 × 22	5.20
2022	20 × 22	
2123	21 × 23	6.10
2224	22 × 24	
2227	22 × 27	6.80
2426	24 × 26	
2427	24 × 27	
2528	25 × 28	7.20
2730	27 × 30	8.50
2732	27 × 32	
3032	30 × 32	
3236	32 × 36	12.50
3641	36 × 41	15.—

Amerik. Maße

625 A - 0810	1/4 × 5/16	2.70
1214	3/8 × 7/16	3.20
1416	7/16 × 1/2	3.50
1618	1/2 × 9/16	
1820	9/16 × 5/8	4.—
1922	19/32 × 11/16	
2022	5/8 × 11/16	
2024	5/8 × 3/4	4.20
2224	11/16 × 3/4	
2226	11/16 × 13/16	4.40
2425	3/4 × 25/32	
2428	3/4 × 7/8	5.20
2526	25/32 × 13/16	
2628	13/16 × 7/8	
2830	7/8 × 15/16	6.10
3032	15/16 × 1	6.80
3236	1 × 1 1/8	7.20
3436	1 1/16 × 1 1/8	8.50
3440	1 1/16 × 1 1/4	
3842	1 3/16 × 1 5/16	
4044	1 1/4 × 1 3/8	12.50
4046	1 1/4 × 1 7/16	
4248	1 5/16 × 1 1/2	
4448	1 3/8 × 1 1/2	
4652	1 7/16 × 1 5/8	



**Ringschlüssel
CHROM-VANADIUM**

625



Engl. Maße

Bestell-Nr.	Zoll	Verchromt Köpfe geschliffen
625W - 0046	1/8 × 3/16	3.—
0068	3/16 × 1/4	3.50
0810	1/4 × 5/16	3.80
1012	5/16 × 3/8	4.—
1214	3/8 × 7/16	5.20
1416	7/16 × 1/2	6.10
1618	1/2 × 9/16	6.80
1620	1/2 × 5/8	
1820	9/16 × 5/8	7.20
1822	9/16 × 11/16	8.50
2024	5/8 × 3/4	
2224	11/16 × 3/4	
2226	11/16 × 13/16	12.50
2428	3/4 × 7/8	
2832	7/8 × 1	15.—



625

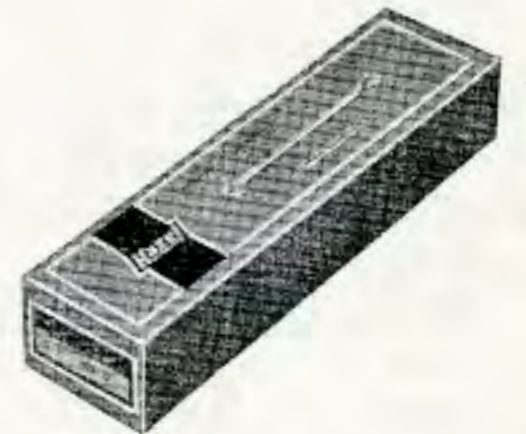

Sätze in hausfarbenen HAZET-Schachteln

Metr. Maße

Bestell-Nr.	Inhalt	Verchromt Köpfe geschliffen
625/6	8 × 9 10 × 11 12 × 13 14 × 15 16 × 17 18 × 19	21.90
625/8	6 × 7 8 × 9 10 × 11 12 × 13 14 × 15 16 × 17 18 × 19 20 × 22	29.80
625/10	6 × 7 8 × 9 10 × 11 12 × 13 14 × 15 16 × 17 18 × 19 20 × 22 21 × 23 24 × 26	42.70
625/12	6 × 7 8 × 9 10 × 11 12 × 13 14 × 15 16 × 17 18 × 19 20 × 22 21 × 23 24 × 26 25 × 28 27 × 32	58.40

Amerik. Maße

625/6 A	3/8—1	27.10
625/8 A	1/4—1 1/4	38.30

Engl. Maße

625/6 W I	1/8—1/2	25.60
------------------	---------	--------------



**Ringschlüssel
CHROM-VANADIUM**

630

lang, hoch gekröpft,
Köpfe dünnwandig



Metr. Maße

Bestell-Nr.	mm/Zoll	Verchromt Köpfe geschliffen
630 - 0067	6 × 7	3.10
0079	7 × 9	3.30
0089	8 × 9	
0810	8 × 10	
0910	9 × 10	3.70
0911	9 × 11	
1011	10 × 11	
1014	10 × 14	
1114	11 × 14	3.90
1213	12 × 13	
1214	12 × 14	
1315	13 × 15	
1415	14 × 15	4.20
1417	14 × 17	4.40
1617	16 × 17	
1719	17 × 19	4.80
1819	18 × 19	
1722	17 × 22	5.30
1922	19 × 22	5.70
2022	20 × 22	
1924	19 × 24	6.80
2123	21 × 23	
2224	22 × 24	
2426	24 × 26	
2227	22 × 27	7.60
2427	24 × 27	
2430	24 × 30	
2527	25 × 27	
2528	25 × 28	8.20
2729	27 × 29	9.—
2730	27 × 30	
2732	27 × 32	9.60
3032	30 × 32	
3036	30 × 36	12.50
3236	32 × 36	
3641	36 × 41	14.50
Amerik. Maße		
630 A - 0810	1/4 × 5/16	3.30
1214	3/8 × 7/16	3.70
1416	7/16 × 1/2	3.90
1618	1/2 × 9/16	
1820	9/16 × 5/8	4.40
1922	19/32 × 11/16	
2022	5/8 × 11/16	
2024	5/8 × 3/4	
2224	11/16 × 3/4	
2425	3/4 × 25/32	4.80
2226	11/16 × 13/16	5.30
2428	3/4 × 7/8	5.70
2526	25/32 × 13/16	
2628	13/16 × 7/8	
2830	7/8 × 15/16	6.80
3032	15/16 × 1	7.60
3236	1 × 1 1/8	8.20
3436	1 1/16 × 1 1/8	9.—
3440	1 1/16 × 1 1/4	9.60
3842	1 3/16 × 1 5/16	
4044	1 1/4 × 1 3/8	12.50
4046	1 1/4 × 1 7/16	
4248	1 5/16 × 1 1/2	
4448	1 3/8 × 1 1/2	
4652	1 7/16 × 1 5/8	



**Ringschlüssel
CHROM-VANADIUM**

630



Engl. Maße

Bestell-Nr.	Zoll	Verchromt Köpfe geschliffen
630W - 0046	1/8 × 3/16	3.70
0068	3/16 × 1/4	3.90
0810	1/4 × 5/16	4.20
1012	5/16 × 3/8	4.40
1214	3/8 × 7/16	5.30
1416	7/16 × 1/2	6.80
1618	1/2 × 9/16	7.60
1620	1/2 × 5/8	
1820	9/16 × 5/8	8.20
1822	9/16 × 11/16	9.—
2024	5/8 × 3/4	9.60
2224	11/16 × 3/4	
2226	11/16 × 13/16	12.50
2428	3/4 × 7/8	
2832	7/8 × 1	14.50



630

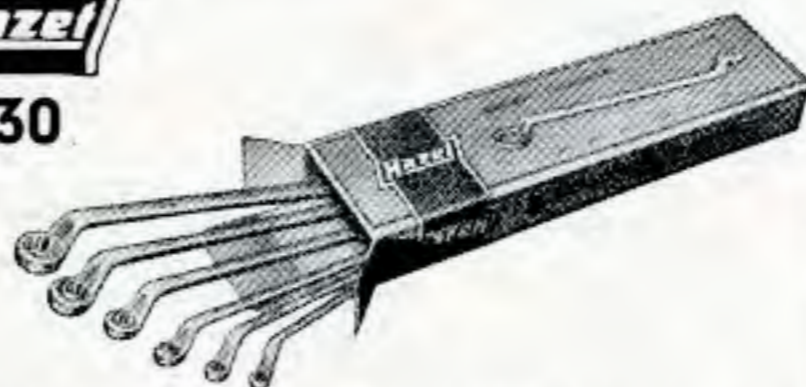

Sätze in hausfarbenen HAZET-Schachteln
Metr. Maße

Bestell-Nr.	Inhalt	Verchr. Köpfe geschliffen
630/6	8 × 9 10 × 11 12 × 13 14 × 15 16 × 17 18 × 19	24.30
630/7	8 × 9 10 × 11 12 × 13 14 × 15 16 × 17 18 × 19 20 × 22	30.—
630/8	6 × 7 8 × 9 10 × 11 12 × 13 14 × 15 16 × 17 18 × 19 20 × 22	33.10
630/10	6 × 7 8 × 9 10 × 11 12 × 13 14 × 15 16 × 17 18 × 19 20 × 22 21 × 23 24 × 26	47.50
630/12	6 × 7 8 × 9 10 × 11 12 × 13 14 × 15 16 × 17 18 × 19 20 × 22 21 × 23 24 × 26 25 × 28 27 × 32	65.30
630/12N	6 × 7 8 × 9 10 × 11 12 × 13 14 × 15 16 × 17 18 × 19 20 × 22 21 × 23 24 × 26 25 × 27 30 × 32	65.30
630/13	6 × 7 8 × 9 10 × 11 12 × 13 14 × 15 16 × 17 18 × 19 20 × 22 21 × 23 24 × 26 25 × 28 27 × 32 36 × 41	79.80

Amerik. Maße

630/5 A	3/8 — 7/8	22.50
630/6 A	3/8 — 1	30.10
630/7 A	1/4 — 1	33.40
630/8 A	1/4 — 1 1/4	43.—
630/9 A	1/4 — 1 7/16	54.90
630/12 A	1/4 — 1 1/4	67.70

Engl. Maße

630/5 W	1/8 — 5/8	27.30
630/6 W I	1/8 — 1/2	28.30
630/6 W II	1/8 — 1	44.90
630/8 W	1/8 — 5/8	44.10
630/12 W	1/8 — 1	93.20



**Ringschlüssel
CHROM-VANADIUM**

630



Sätze auf Dekorations- und Verkaufstafeln

Metr. Maße

Bestell-Nr.	Sortimente	Verchromt Köpfe geschliffen
D 630/12	6 × 7 — 27 × 32	65.30
DV 630/39	6 × 7 — 27 × 32	193.10
Amerik. Maße		
D 630/12 A	1/4 — 1 1/4	67.70
DV 630/38 A	1/4 — 1 1/4	197.40



**Ringschlüssel
CHROM-VANADIUM**

635

kurz, gekröpft



Metr. Maße

Bestell-Nr.	mm/Zoll	Verchromt Köpfe geschliffen
635 - 0910	9 × 10	2.70
1214	12 × 14	3.30
1415	14 × 15	3.80
1719	17 × 19	4.10

Amerik. Maße

635 A - 1214	3/8 × 7/16	2.70
1618	1/2 × 9/16	3.30
1820	9/16 × 5/8	3.80
2022	5/8 × 11/16	4.10
2024	5/8 × 3/4	

Engl. Maße

635W - 0046	1/8 × 3/16	2.70
0068	3/16 × 1/4	3.30
0810	1/4 × 5/16	3.80
1012	5/16 × 3/8	4.10
1214	3/8 × 7/16	4.50



635

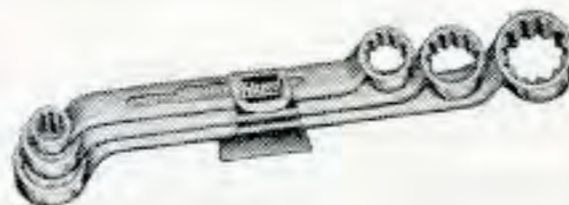

Sätze in Klammern und hausfarbenen
HAZET-Schachteln

Metr. Maße

Bestell-Nr.	Inhalt	Verchromt Köpfe geschliffen
635/3	9 × 10 12 × 14 17 × 19	10.10

Amerik. Maße

635/3 A	3/8 — 11/16	10.10
----------------	-------------	--------------

Engl. Maße

635/3 W	1/8 — 3/8	10.10
----------------	-----------	--------------



**Ringschlüssel
CHROM-VANADIUM**
schwer, gekröpft

640



Metr. Maße

Bestell-Nr.	mm/Zoll	Verchromt
640 - 24	24	16.—
27	27	18.10
30	30	19.60
32	32	20.80
36	36	22.40
41	41	22.80
46	46	23.60
50	50	25.80
55	55	30.60
60	60	34.80
65	65	37.80
70	70	41.50
75	75	45.60
80	80	50.20

Amerik. Maße

640 A - 32	1	16.—
34	1 1/16	18.10
36	1 1/8	19.60
40	1 1/4	20.80
46	1 7/16	22.40
52	1 5/8	22.80
58	1 13/16	23.60
64	2	25.80
70	2 3/16	30.60
76	2 3/8	34.80
82	2 9/16	37.80
88	2 3/4	41.50
94	2 15/16	45.60
100	3 1/8	50.20

Engl. Maße

640 W - 16	1/2	16.—
18	9/16	18.10
20	5/8	19.60
22	11/16	19.60
24	3/4	20.80
26	13/16	22.40
28	7/8	22.40
30	15/16	22.80
32	1	22.80
36	1 1/8	23.60
40	1 1/4	25.80
44	1 3/8	30.60
48	1 1/2	34.80
52	1 5/8	37.80
56	1 3/4	41.50
64	2	50.20



Aufsteckrohre

640



Metr. Maße

Bestell-Nr.	für Schlüssel	Preis
640 - 2430	24 - 30	10.50
3241	32 - 41	13.10
4655	46 - 55	14.50
6080	60 - 80	18.50
6080 Lg.	60 - 80	31.80

Amerik. Maße

640 A - 2430	1 — 1 1/8	10.50
3241	1 1/4 — 1 5/8	13.10
4655	1 13/16 — 2 3/16	14.50
6080	2 3/8 — 3 1/8	18.50
6080 Lg.	2 3/8 — 3 1/8	31.80

Engl. Maße

640 W - 2430	1/2 — 11/16	10.50
3241	3/4 — 1	13.10
4655	1 1/8 — 1 3/8	14.50
6080	1 1/2 — 2	18.50
6080 Lg.	1 1/2 — 2	31.80



**Ringschlüssel
CHROM-VANADIUM**

640

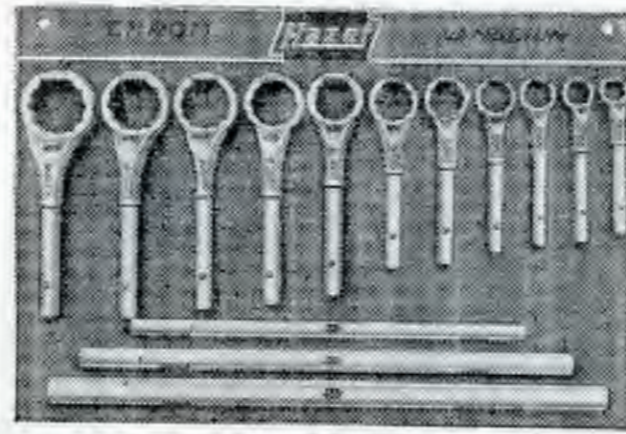

Sätze (R = mit Aufhängetafel)

Metr. Maße

Bestell-Nr.	Inhalt	Verchromt
640/14	32 — 80	402.—
R 640/14	32 — 80	440.—

Amerik. Maße

640/14 A	1 1/4 — 3 1/8	402.—
R 640/14 A	1 1/4 — 3 1/8	440.—

Engl. Maße

640/14 W	3/4 — 2	379.20
R 640/14 W	3/4 — 2	417.20



**Gelenkschlüssel
CHROM-VANADIUM**

645

eingebaute Arretierung

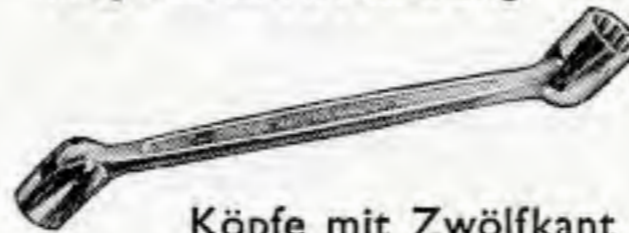

Köpfe mit Zwölfkant

Metr. Maße

Bestell-Nr.	mm/Zoll	Verchromt Köpfe Hochglanz
645 - 0089	8 x 9	7.10
1011	10 x 11	7.80
1213	12 x 13	9.20
1415	14 x 15	9.90
1617	16 x 17	10.60
1819	18 x 19	11.20
2022	20 x 22	12.80
2123	21 x 23	13.80
2427	24 x 27	16.—
3032	30 x 32	22.20

Amerik. Maße

645 A - 1214	3/8 x 7/16	7.10
1618	1/2 x 9/16	9.20
1922	19/32 x 11/16	10.60
2022	5/8 x 11/16	10.60
2024	5/8 x 3/4	11.20
2428	3/4 x 7/8	12.80
2628	13/16 x 7/8	12.80
3032	15/16 x 1	16.—
3440	1 1/16 x 1 1/4	22.20

Engl. Maße

645 W - 0046	1/8 x 3/16	7.10
0810	1/4 x 5/16	9.20
1214	3/8 x 7/16	12.80
1618	1/2 x 9/16	16.—



645



Sätze in hausfarbenen HAZET-Schachteln oder Plastic-Taschen (P)

Metr. Maße

Bestell-Nr.	Inhalt	Verchromt Köpfe Hochglanz
645/7	8 x 9 10 x 11 12 x 13 14 x 15 16 x 17 18 x 19 20 x 22	68.60
645/10	8 x 9 10 x 11 12 x 13 14 x 15 16 x 17 18 x 19 20 x 22 21 x 23 24 x 27 30 x 32	120.60

Amerik. Maße

645/7 A	3/8 — 1 1/4	89.10
P 645/3 A	3/8 — 3/4	32.80

Engl. Maße

645/4 W	1/8 — 9/16	45.10
---------	------------	-------



**Gelenkschlüssel
CHROM-VANADIUM**

645



Sätze auf Dekorations- und Verkaufstafeln

Metr. Maße

Bestell-Nr.	Sortimente	Verchromt Köpfe Hochglanz
D 645/10	8 x 9 — 30 x 32	120.60
DV 645/33	8 x 9 — 30 x 32	368.—

Amerik. Maße

D 645/7 A	3/8 — 1 1/4	89.10
DV 645/22 A	3/8 — 1 1/4	256.20



**Reifenheber
CHROM-VANADIUM**

650

I-Profil



Bestell-Nr.	mm	Zoll	Verchromt
650 - 6	150	6	2.20
8	200	8	2.40
12	300	12	2.90
16	400	16	3.80
20	500	20	5.10

652

gebogen



Bestell-Nr.	mm	Zoll	Preis
652 - 24	600	24	8.40

653

für schlauchlose Reifen



653 - 18	455	18	7.40
----------	-----	----	------



**Kreuzschlüssel
VERGÜTUNGSSTAHL**

705

„Popular“
für Pkw



Bestell-Nr.	mm/Zoll	Silbergrau lackiert
705	17 x 19 x 20,64 x 22	7.90
705 - 19	19 x 19 x 19 x 19	7.90
705 - 1719	17 x 17 x 19 x 19	7.90
705 A	5/8 x 3/4 x 13/16 x 7/8	7.90
705 W	5/16 x 3/8 x 7/16 x 1/2	7.90

705 S / 705 AS vorerst nicht lieferbar

Bestell-Nr.	mm/Zoll	Verchromt
705 V **	17 x 19 x 20,64 x 22	10.50
705 AV**	5/8 x 3/4 x 13/16 x 7/8	10.50

715 / 715 A vorerst nicht lieferbar



720

**Kreuzschlüssel
CHROM-VANADIUM**

für Lkw

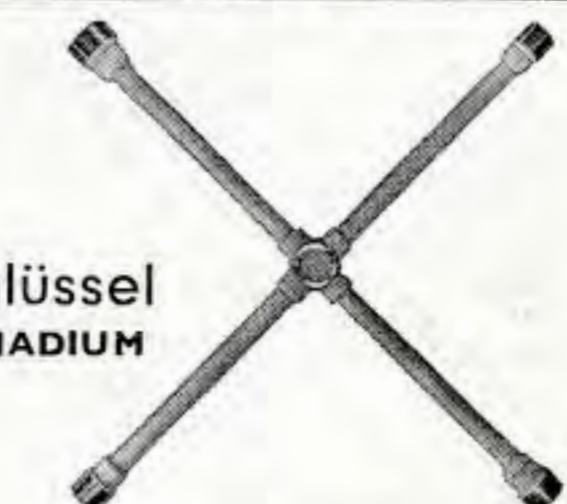

Bestell-Nr.	mm/Zoll	Verchromt Köpfe geschliffen
720	24 x 27 x 32 x 38	45.60
720 - 30	24 x 27 x 30 x 32	45.60
720 A	15/16 x 1 1/16 x 1 1/4 x 1 1/2	45.60

Hazel Flachmeißel
CHROM-VANADIUM

730
731

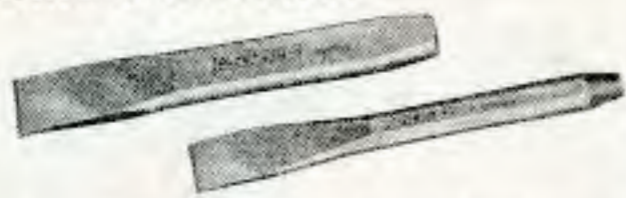

Bestell-Nr.	mm	Preis
730 - 1	100 x 15	2.40
2	125 x 18	2.60
3	150 x 18	2.80
4	150 x 20	3.40
5	175 x 22	4.10
6	200 x 24	4.90
7	250 x 26	5.80
731 - 1	120 x 10	2.—
2	130 x 11	2.20
3	130 x 12	2.50
4	140 x 14	2.60
5	150 x 15	3.—
6	150 x 16	3.—
7	160 x 18	3.60
8	180 x 20	4.—
9	200 x 22	4.20

Hazel Kreuzmeißel
CHROM-VANADIUM

740
741



740 - 1	100 x 6	2.40
2	125 x 7	2.60
3	150 x 8	2.80
4	150 x 8	3.40
5	175 x 9	4.10
6	200 x 10	4.90
7	250 x 12	5.80
741 - 1	130 x 4	2.20
2	130 x 5	2.50
3	140 x 6	2.70
4	150 x 7	2.90
5	160 x 8	3.50
6	180 x 9	4.20
7	200 x 10	4.80

Hazel Durchschläger, Körner,
Splintentreiber
CHROM-VANADIUM

745-
748



745 - 1	120 x 1 x 10	2.—	
2	120 x 2 x 10		
3	120 x 3 x 10		
4	120 x 4 x 10		
5	120 x 5 x 10		
6	120 x 6 x 10		
7	120 x 7 x 10		
8	120 x 8 x 10		
9	120 x 1 x 12	2.40	
10	120 x 2 x 12		
11	120 x 3 x 12		
12	120 x 4 x 12		
13	120 x 5 x 12		
14	120 x 6 x 12		
15	120 x 7 x 12		
16	120 x 8 x 12		
17	120 x 9 x 12		
18	120 x 10 x 12		
19	150 x 4 x 13	2.80	
746 - 1	120 x 10	1.70	
2	120 x 12	2.30	
748 - 1	115 x 2	2.60	
2	125 x 3	2.70	
3	150 x 2,5	2.90	
4	150 x 3		
5	150 x 4		
6	150 x 5		
7	150 x 6		
8	150 x 8		
9	160 x 5		3.—
10	180 x 6		3.70
11	200 x 8	3.90	

Hazel Sätze mit Meißel,
Durchschläger, Körner
und Splintentreiber
auf Holzständer

750
751

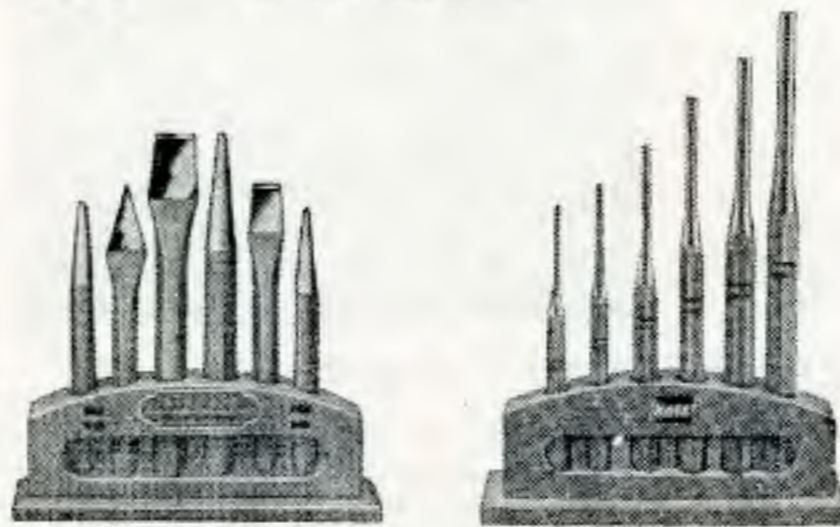

Bestell-Nr.	Inhalt	Preis
750/6	731 - 2 731 - 5	13.90
	741 - 1 745 - 3	
	745 - 19 746 - 1	
750/6 I	730 - 3 730 - 6	17.20
	740 - 3 745 - 2	
	745 - 12 746 - 2	
751/6	748 - 1 748 - 2	18.80
	748 - 5 748 - 9	
	748 - 10 748 - 11	
	748 - 3 — 748 - 8	
751/6 I		17.40

Hazel Universal-Gripzange
CHROM-VANADIUM

756



Bestell-Nr.	mm	Zoll	Glanz- vernickelt
756	165	6 1/2	8.40

Hazel Universal-Gripzangen
CHROM-VANADIUM
mit Auslösehebel
Geschmiedete Backen
Drahtschneider

757

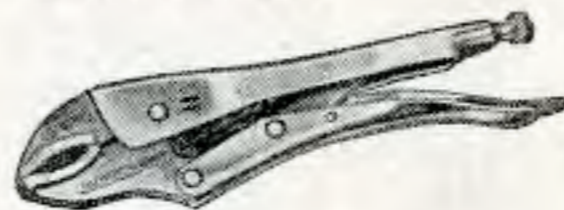

757 - 7	180	7	9.50
10	250	10	11.20

Hazel Schweißer-Gripzange
CHROM-VANADIUM
mit Auslösehebel

758-1



758 - 1	280	11	14.40
---------	-----	----	-------

Hazel Gripzange
CHROM-VANADIUM

758-2

für sperrige Werkstücke
mit Auslösehebel



758 - 2	280	11	14.90
---------	-----	----	-------

Hazel Schnellspann-
Universalzange
CHROM-VANADIUM
mit durchgestecktem
Gewerbe und Brennerloch

759

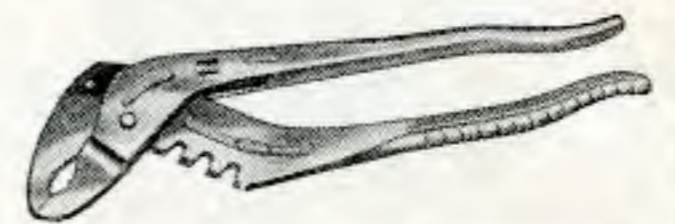

Bestell-Nr.	mm	Zoll	Hochglanz verchromt
759	250	10	14.90

Hazel Universalzangen
CHROM-VANADIUM

760

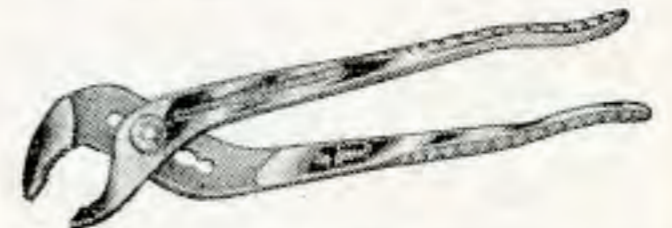

Bestell-Nr.	mm	Zoll	Hochglanz verchromt	Verchromt
760 - 1	115	4 1/2	5.—	—
3	240	9 1/2	8.20	6.—
4	375	15	19.90	15.60

mit Handschutz-Isolierung 10000 V

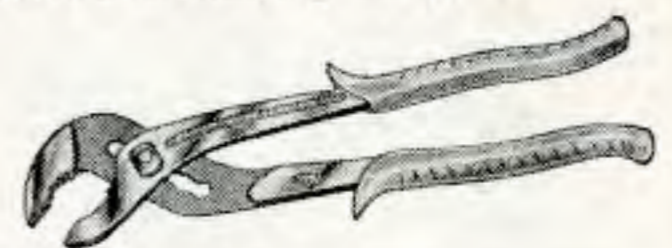

760 - 11	115	4 1/2	7.—	—
33	240	9 1/2	11.20	9.—
44	375	15	24.90	20.50

R 760	Reklameständ. mit 3 St. 9 1/2"		24.60	18.—
R 760 I	dto. isoliert		33.60	27.—

Hazel Universalzange
CHROM-VANADIUM
mit 5 Führungsgrillen

760 N

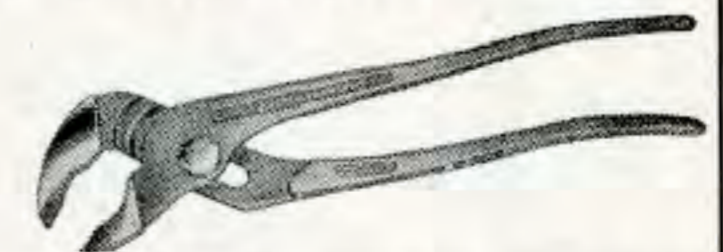

Bestell-Nr.	mm	Zoll	Hochglanz verchromt
760 N **	240	9 1/2	12.40

Hazel Zündkerzenschlüssel
mit umlegbarem Griff

761



Bestell-Nr.	mm/Zoll	Verchromt Köpfe geschliffen
761	21 x 26	4.30
761 A	13/16 x 1	4.30

Hazel Zündkerzenschlüssel
mit Kardangelenk

762

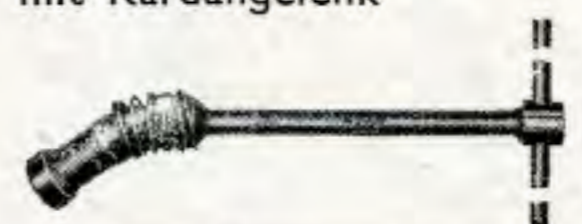

762	21 (13/16)	10.60
-----	------------	-------

Hazel Zündkerzenschlüssel
besonders lang

763

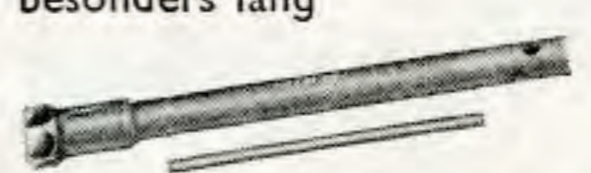

763	21 (13/16)	7.90
-----	------------	------

Hazel Zündkerzenschlüssel
mit Kugelkopf (DBGM)
764



Bestell-Nr.	mm/Zoll	Verchromt
764	21 (13/16)	8.40

Hazel Zündkerzenschlüssel
mit Kugelgelenk (DBGM)
765



765	21 u. 26	14.20
-----	----------	-------

Hazel Zündkerzenschlüssel
für Motorrad und Motorroller
766



766	21 (13/16)	3.20
-----	------------	------

Hazel Zündkerzenschlüssel
mit Kugelgelenk
767



767	21 (13/16)	6.90
-----	------------	------

Hazel Radmutternschlüssel
CHROM-VANADIUM
768 Pkw

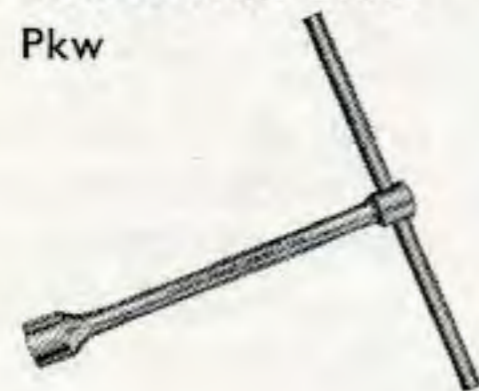

Bestell-Nr.	mm/Zoll	Verchromt Köpfe geschliffen
768 - 17 **	17	8.40
19	19 (3/4)	8.40

Hazel Radmutternschlüssel
CHROM-VANADIUM
769 Lkw

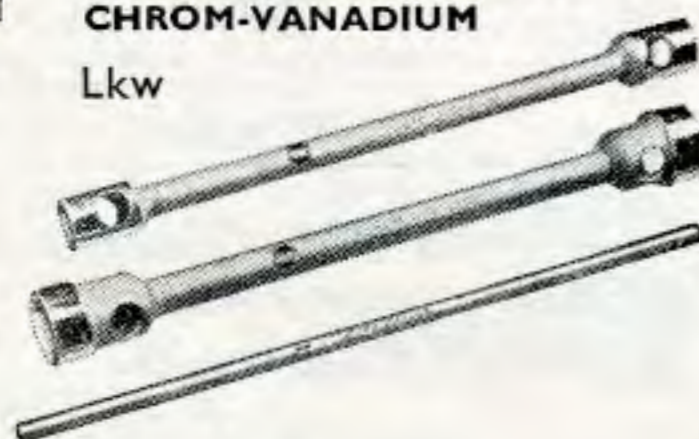

769 - 1	24 x 27	11.40
769 - 2	28 x 33 (5/8 x 3/4W)	12.60
769 - 3	32 x 38	14.20
769 - 1 A	15/16 x 11/16	11.40
769 - 3 A	11/4 x 11/2	14.20
769 - 4	Stecker 18 Ø	6.60

Hazel Radschraubenkurbel
CHROM-VANADIUM
772 DBP Nr. 912800



Bestell-Nr.	mm/Zoll	Verchromt
772	19 (3/4)	8.40

Hazel Universal-Radabzieher
CHROM-VANADIUM
781
Zugarme verschieb- und
auswechselbar
Lochkreisdurchmesser:
Minimum/Maximum 90-200 mm



Bestell-Nr.		Verchromt
781 - 3	m. 3 Zugarmen u. Schlaggriff	74.20
781 - 5	m. 5 Zugarmen u. Schlaggriff	95.40
781 - 7	lose Zugarme	10.60
781 - 9	lose Schlaggriffe	7.70

Hazel Radabzieher
SPEZIALSTAHL
782
783 2- und 3armig

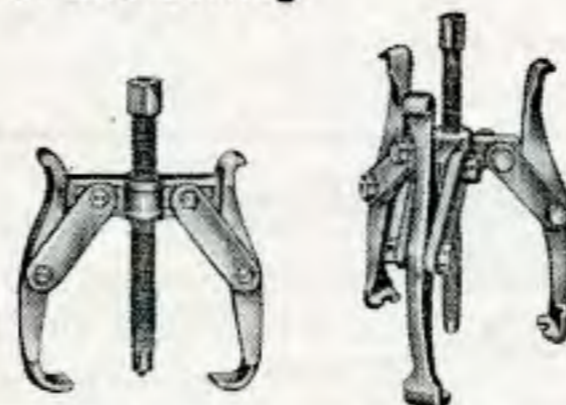

Bestell-Nr.	Spann-		Silbergrau lackiert
	Weite mm	Tiefe mm	
782 - 15	150	80	32.90
20	200	130	55.80
783 - 15	150	80	46.80
20	200	130	73.20

Hazel Radabzieher
SPEZIALSTAHL
784
785 2- und 3armig, besonders stark

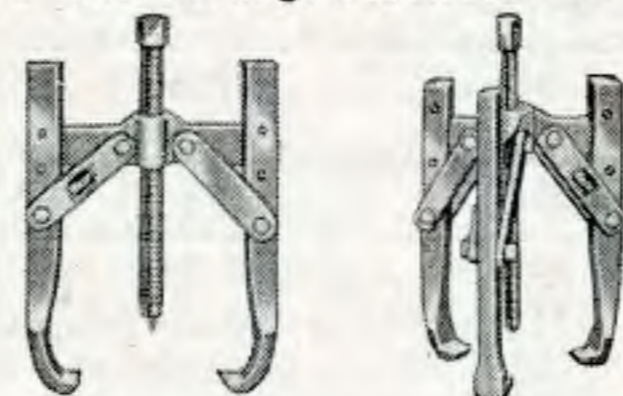

784	300	—	73.20
785	300	—	103.60

Hazel Dreiarmlige Abzieher
SPEZIALSTAHL
786
als Innen- und Außen-Abzieher
zu verwenden



786 - 1	120	80	42.80
2	160	115	68.80
3	225	170	94.80

Hazel Zweiarmlige Universal-
Radabzieher
787 SPEZIALSTAHL

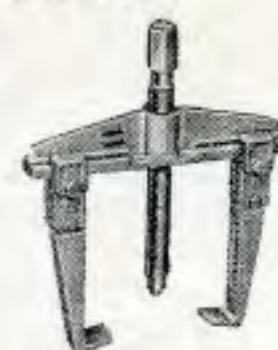

Bestell-Nr.	Spann-		Silbergrau lackiert
	Weite mm	Tiefe mm	
787 - 10	80	90	37.80
15	130	90	40.60
20	160	150	64.40
25	220	150	74.—
30	250	200	116.—
35	370	200	131.—
40	550	225	150.—

Lose Abzugshaken

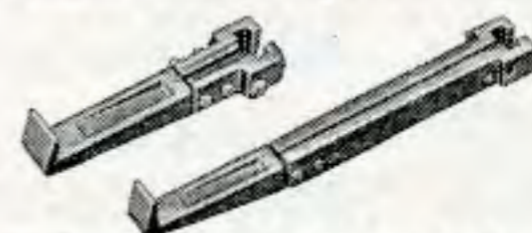

mit normalen Gleitschuhen

Bestell-Nr.	mm	Preis per Paar
787 - 1015	90	21.—
2025	150	36.20
3035	200	50.40
4000	225	59.60

mit extra langen Gleitschuhen

787 - 1015 Lg.	190	26.80
2025 Lg.	300	44.80
3035 Lg.	300	63.80
3035/4 Lg.	400	72.80
3035/5 Lg.	500	81.20
4000 Lg.	300	70.60
4000/4 Lg.	400	78.40
4000/5 Lg.	500	85.60

Hazel Innen-Auszieher
SPEZIALSTAHL
788



Bestell-Nr.	Spannweite mm	Fein blank poliert
788 - 1	12 - 17	15.90
2	16 - 21	20.—
3	20 - 28	24.60
4	27 - 37	27.40
5	35 - 47	31.60
6	45 - 58	39.60
7	56 - 70	51.40
8	70 - 100	78.—

Gegenstütz-Vorrichtg.

Bestell-Nr.	für Auszieher	Silbergrau lackiert
788 - 10	788 - 1, 2 u. 3	18.90
20	4, 5, 6 u. 7	32.—
30	8	63.—

Hazel Lenkradabzieher
SPEZIALSTAHL
789
für alle Lenksäulen 32-57 mm Ø

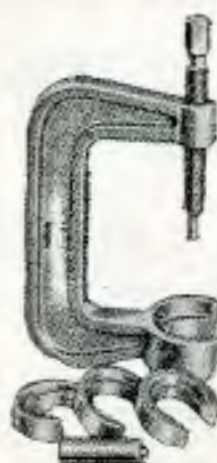

789	mit 5 auswechselbaren Einlegeringen	53.60
-----	--	-------



Kolbenringzangen

790

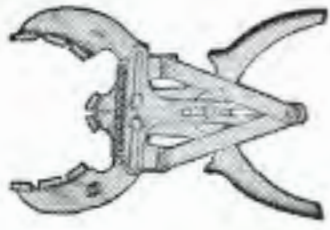

Bestell-Nr.	für Kolbenringe	Glanzvernickelt
790 - 1	50 — 100	8.80
790 - 1 a	65 — 110	9.60
790 - 2	110 — 150	11.60



Ventilkeilpistole

zusammen mit 792 zu verwenden

791



Bestell-Nr.	mm	Glanzvernickelt
791	195	6.80



Ventilfeder-Spannapparat

zusammen mit 791 zu verwenden

792



792 - 1	290	21.30
792 - 2	380	36.40



Ventilfeder-Hebezangen

für untengesteuerte Ventile

793



793 - 1	250	14.60
793 - 2	200	15.30



Kolbenring-Spannbänder

mit Sperrklinke und Spanschlüssel

794



Bestell-Nr.	Spannend mm/Zoll	Preis
794 - 01	40 — 75 1 1/2 — 3	5.20
1	60 — 125 2 1/8 — 5	9.—
2	90 — 175 3 1/2 — 7	10.60
3	90 — 175 3 1/2 — 7	21.10



Ventileinschleifer mit Saugnapf

795



795 - 1	20	2.—
2	25	2.40
3	30	2.50
4	37	2.70



Bremsefederzange CHROM-VANADIUM

796

für aufgenietete Bremsbeläge



Bestell-Nr.	mm	Zoll	Verchromt
796	215	8 1/2	6.60



Bremsefederzange CHROM-VANADIUM

797

mit beweglichem Teller, für aufgenietete und geklebte Bremsbeläge



797	340	13 1/2	11.60
-----	-----	--------	-------



Schlauchklemmen-Zangen CHROM-VANADIUM

798

drehbare Backen



mit Feststellvorrichtung

798	205	8	10.30
798 - 1**	280	11	13.40
798 - 2**	415	16 1/2	14.80



Batteriedienst-Behälter

aus säurefestem Gummi für ca. 4 Liter destilliertes Wasser

802

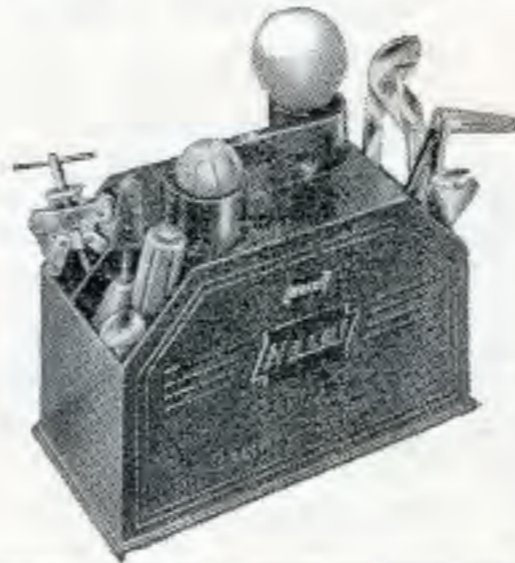

Bestell-Nr.	Inhalt	Preis
802	9teilig	105.80
802 L	leer	42.90

Bestell-Nr.	Inhalt	Preis
450	Gabelschlüssel 10x14	2.—
760	Universalzange 9 1/2"	6.—
811	Schraubenzieher 100x6	2.90
1848	Batteriezange 8"	9.60
8020	Batteriefüller	4.70
8021	Säureprüfer	6.70
8022	Polklemmenabzieher	13.10
8023	Polklemmenzange 7 1/2"	14.80
8024	Pol- und Klemmen-Reinigungsbürste	3.10

Batterie-Zellenprüfer



Bestell-Nr.	abschaltbare Widerstände	Preis
8025 - 1	1	30.60
8025 - 2	2	38.70



Werkzeugausrüstungen CHROM-VANADIUM

804

in fünfteiligen, stabilen Werkzeugkästen, verschließbar



Bestell-Nr.	Inhalt	Verchromt
804 - 1	84 teilig	445.—
804 - 1 A	74 teilig	339.—
804 - 1 W	63 teilig	308.—
804 - 2	60 teilig	272.—
804 - 2 A	57 teilig	267.—
804 - 2 W	49 teilig	246.—
804 - 4	56 teilig	302.—
804 - 4 A	52 teilig	262.—
804 - 4 W	41 teilig	226.—
804 L	leer	40.80



Motorrad-Werkzeugsatz CHROM-VANADIUM

805

in Plastic-Tasche



805	10 teilig	25.20
-----	-----------	-------



Herrenfahrer-Werkzeugsatz CHROM-VANADIUM

806

in Plastic-Tasche



806	9 teilig	31.60
806 A	9 teilig	31.60



Herrenfahrer-Werkzeugsatz CHROM-VANADIUM

808

in Vollrindleder-Tasche mit Reißverschluss



808	15 teilig	115.20
808 A	15 teilig	116.—



Großer Werkzeugsatz CHROM-VANADIUM

809

in Plastic-Tasche

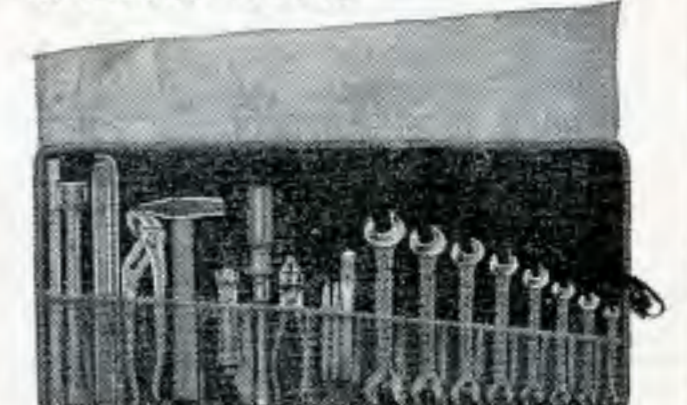

809	20 teilig	78.40
809 A	20 teilig	79.40

Hazel Kleine Werkzeugsätze
CHROM-VANADIUM

810 in Plastic-Taschen

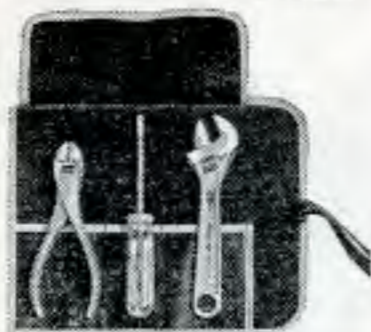

Bestell-Nr.	Inhalt	Preis
810 - 1	1 1850 - 2	10.80
	1 832 - 3	
810 - 2	1 760 - 1	8.90
	1 832 - 3	
810 - 3	1 1801 - 1	22.40
	1 832 - 3	
	1 180 - 6	
810 - 4	1 1850 - 2	19.70
	1 832 - 3	
	1 180 - 6	
810 - 5	1 760 - 1	17.80
	1 832 - 3	
	1 180 - 6	

Hazel Werkstatt-Schraubenzieher
CHROM-VANADIUM

811

durchgehende Klinge,
Holzheft



Bestell-Nr.	mm	Preis
811 - 1	75 x 5	2.30
2	100 x 5	2.50
3	100 x 6	2.90
4	150 x 6	3.10
5	100 x 7	3.10
6	125 x 7	3.20
7	150 x 7	3.40
8	100 x 8	3.40
9	150 x 8	3.70
10	200 x 8	3.90
11	200 x 9	4.—
12	150 x 10	4.20
13	200 x 10	4.50
14	250 x 10	4.70
15	200 x 12	5.20
16	250 x 12	5.60

812 Motorrad-Schraubenzieher
CHROM-VANADIUM

Holzheft



Bestell-Nr.	mm	Preis
812	50 x 6	1.30

813 Elektriker-Schraubenzieher
CHROM-VANADIUM

Holzheft



Bestell-Nr.	mm	Preis
813 - 1	60 x 2,5	1.20
2	80 x 3	1.30
3	100 x 3,5	1.40
4	120 x 4	1.60
5	140 x 5	1.80
6	160 x 5	2.—

814 Kreuzschlitz-Schraubenzieher
CHROM-VANADIUM

Holzheft

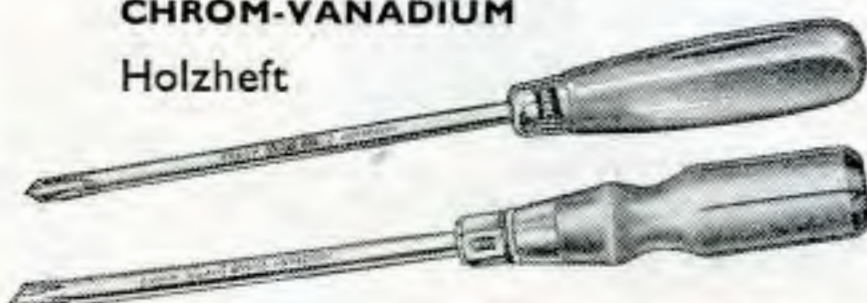

Bestell-Nr.	mm	Preis
814 - 0	60 x 3	1.90
1	95 x 4	2.—
2	140 x 6	2.80
3	160 x 8	5.20
4	180 x 11	7.10
Kurze Form		
814 - 01	30 x 4	1.70
02	40 x 6	1.90
02a	46 x 6	1.90

Hazel Schraubenzieher
CHROM-VANADIUM

815 durchgehende Vierkantklinge
mit Sechskant, Holzheft



Bestell-Nr.	mm	Preis
815 - 1	100 x 5,5	3.50
2	125 x 7	4.40
3	150 x 9	5.80
4	175 x 10	6.70
5	200 x 11	7.80
6	250 x 13	8.80

818 Winkelschraubenzieher
CHROM-VANADIUM

Klingenstellung 90° und 45°



Bestell-Nr.	90°	45°	mm	Preis
818 - 1	818 - 11	100 x 4	2.70	
2	22	125 x 6	3.—	
3	33	150 x 8	3.50	
4	44	175 x 10	4.50	
5	55	200 x 13	5.20	

819 Kreuzschlitz-Winkelschraubenzieher
CHROM-VANADIUM



Bestell-Nr.	mm	Preis
819 - 1	100	2.80
2	150	4.10

Hazel Schaber
CHROM-VANADIUM

820-824 Holzheft

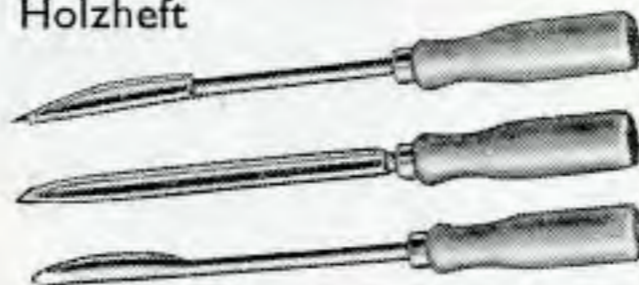

Bestell-Nr.	mm	Preis
820 - 1	125	3.80
2	150	4.20
3	200	5.30
4	250	6.40
821 - 1	150	4.50
2	200	5.30
3	250	5.80
4	300	6.40
824 - 1	125	3.90
2	150	4.50
3	200	5.50
4	250	6.70

Hazel Werkstatt-Schraubenzieher
CHROM-VANADIUM

830

mit runder Klinge,
Transparentheft

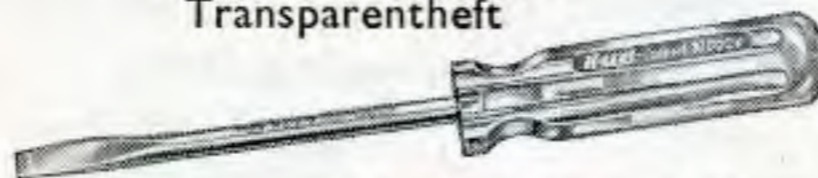

Bestell-Nr.	mm	Preis
830 - 1	75 x 5	2.70
2	100 x 5	2.80
3	100 x 6	3.40
4	150 x 6	3.50
5	100 x 7	3.50
6	125 x 7	3.70
7	150 x 7	3.80
8	100 x 8	3.80
9	150 x 8	4.20
10	200 x 8	5.—
11	200 x 9	5.10
12	150 x 10	5.20
13	200 x 10	5.50
14	250 x 10	6.10
15	200 x 12	6.20
16	250 x 12	6.70

Hazel Werkstatt-Schraubenzieher
CHROM-VANADIUM

831 mit vierkantiger Klinge,
Transparentheft

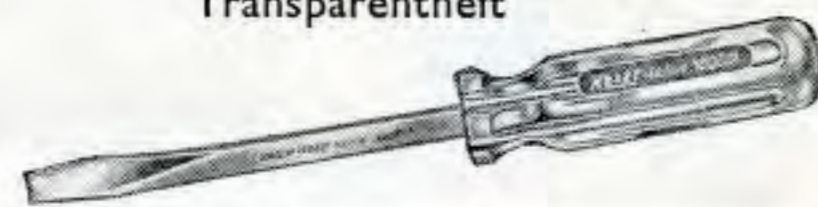

Bestell-Nr.	mm	Preis
831 - 1	75 x 6	2.90
2	100 x 6	3.10
3	150 x 6	3.90
4	100 x 8	4.10
5	150 x 8	5.—
6	200 x 8	5.60
7	150 x 10	6.20
8	200 x 10	6.70
9	250 x 10	7.10

832 Elektriker-Schraubenzieher
CHROM-VANADIUM

Transparentheft



Bestell-Nr.	mm	Preis
832 - 1	60 x 2,5	1.70
2	80 x 3	1.80
3	80 x 3,5	1.90
4	100 x 4	2.30
5	120 x 4	2.40
6	140 x 5	2.80
7	160 x 5	3.—
8	200 x 5	3.10

833 Elektriker-Schraubenzieher
CHROM-VANADIUM

bis an die Schneide isoliert,
Transparentheft

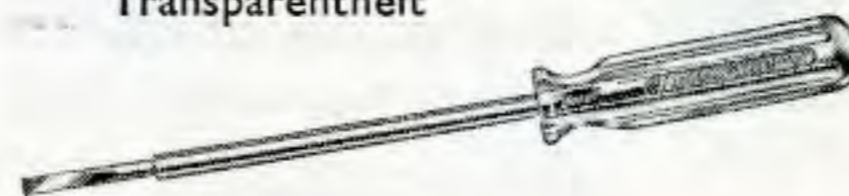

Bestell-Nr.	mm	Preis
833 - 1	60 x 2,5	2.—
2	80 x 3	2.30
3	80 x 3,5	2.50
4	100 x 4	2.70
5	120 x 4	2.80
6	140 x 5	3.20
7	160 x 5	3.70

834 Schraubenzieher
CHROM-VANADIUM

für Vergaser, kurze Form,
Transparentheft

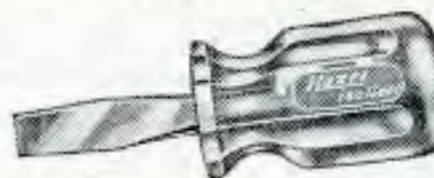

Bestell-Nr.	mm	Preis
834 - 1	25 x 5	2.60
2	25 x 6	2.70
3	25 x 8	3.50
4	25 x 10	3.70

835 Kreuzschlitz-Schraubenzieher
CHROM-VANADIUM

Transparentheft



Bestell-Nr.	mm	Preis
835 - 0	70 x 3	2.60
1	105 x 4	2.80
2	155 x 6	3.70
3	185 x 8	6.20
4	215 x 10	8.20
Kurze Form		
835 - 01	30 x 4	2.90
02	40 x 6	3.50



Werkstatt-Schraubenzieher
CHROM-VANADIUM

836

Vierkantklinge mit Sechskant,
Transparentheft



Bestell-Nr.	mm	Preis
836 - 1	100 x 6	3.90
2	125 x 7	4.90
3	150 x 9	6.30
4	175 x 10	8.—
5	200 x 11	8.80



Zündkerzenprüfer
CHROM-VANADIUM

837

mit Neonröhre,
Transparentheft



837 - 1	50 x 3	2.40
1 a	100 x 4	3.50
2	100 x 5	3.90



Ventileinstell-Schraubenzieher
CHROM-VANADIUM

838

für hängende Ventile,
Transparentheft



838	170	5.60
-----	-----	------



Schraubenausdreher
CHROM-VANADIUM

840



Bestell-Nr.	Ø mm	Länge mm	Preis
840 - 1	1,4-3,6	50	0.90
2	2,1-4,9	57	1.10
3	3,1-6,5	64	1.30
4	4,8-8,8	71	1.60
5	6,2-11	78	1.90
6	9,4-15	85	3.—
7	12,7-19	92	4.30
8	17,5-24	100	6.—
9	24 -31	112	9.50
10	31 -39	122	21.90
11	39 -48	134	31.20
12	48 -59	150	47.20



Sätze in Plastic-Behältern

Bestell-Nr.	Inhalt	Preis
840 - 15	1 - 5	7.50
16	1 - 6	11.—
18	1 - 8	21.40



Stehbolzenauszieher
SPEZIALSTAHL

845

1/2" □



Bestell-Nr.	mm/Zoll	Blankpoliert
845 - 13	13 1/2	18.10
19	19 3/4	27.80
25	25 1	40.70



Steckschlüsselsätze
CHROM-VANADIUM

850-852

1/4" □

mit Sechskant-Einsätzen



Metr. Maße

Bestell-Nr.	Inhalt	Verchromt Köpfe geschliffen
850	10 Einsätze 4 4,5 5 5,5 6 7 8 9 10 11 865/5", 866/5", 867/2", 868/6"	40.40
851	wie vor, zusätzlich 760/4 1/2", 833 - 1	48.40
852	10 Einsätze 4 4,5 5 5,5 6 7 8 9 10 11 863/4 1/2", 864/6", 865/5", 866/5", 867/2", 868/6", 869	72.60

Amerik. Maße

850 A	3/16 - 7/16	36.80
851 A	3/16 - 7/16	44.80
852 A	3/16 - 7/16	68.80

Engl. Maße

850 W	8 BA - 0 BA	38.60
851 W	8 BA - 0 BA	46.60
852 W	8 BA - 0 BA	70.60



Steckschlüsselsätze
CHROM-VANADIUM

853

1/4" □

mit Sechskant-Einsätzen

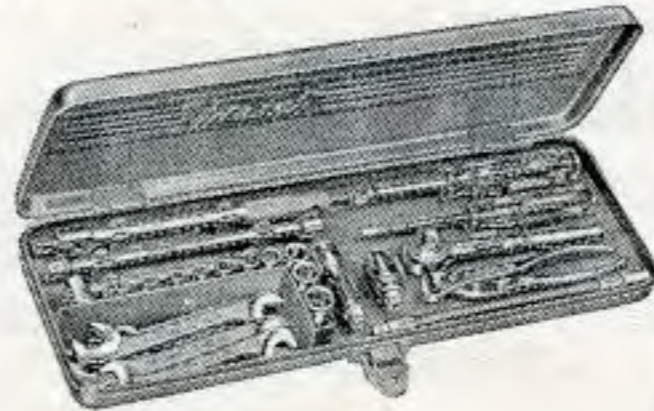

Metr. Maße

853	12 Kleingabelschlüssel 330/3,5-12 10 Einsätze 4 4,5 5 5,5 6 7 8 9 10 11 863/4 1/2", 864/6", 865/5", 866/5", 867/2", 868/6", 869, 870/6", 760/4 1/2", 833 - 1	117.20
-----	---	--------

Amerik. Maße

853 A	3/16 - 7/16	106.60
-------	-------------	--------

Engl. Maße

853 W	8 BA - 0 BA	110.—
-------	-------------	-------



Sechskant-Einsätze
CHROM-VANADIUM

850

1/4" □



Metr. Maße

Bestell-Nr.	mm	Verchromt Köpfe geschliffen
850 - 04	4	1.80
45	4,5	
05	5	
55	5,5	
06	6	
07	7	
08	8	
09	9	
10	10	
11	11	



Sechskant-Einsätze
CHROM-VANADIUM

850

1/4" □



Amerik. Maße

Bestell-Nr.	Zoll	Verchromt Köpfe geschliffen
850 A - 06	3/16	1.80
07	7/32	
08	1/4	
09	9/32	
10	5/16	
11	11/32	
12	3/8	
14	7/16	

Engl. Maße

850 W - 08	8 BA	1.80
07	7 BA	
06	6 BA	
05	5 BA	
04	4 BA	
03	3 BA	
02	2 BA	
01	1 BA	
00	0 BA	



Achtkant-Einsätze
CHROM-VANADIUM

850

1/4" □



Amerik. Maße

850 AK - 08	1/4	1.80
10	5/16	
12	3/8	



**Betätigungs-
werkzeuge**
CHROM-VANADIUM

858-870

1/4" □



Bestell-Nr.	Bezeichnung	Verchromt Köpfe geschliffen
858 R I	Reduziereins. 1/4 x 3/8"	3.—
858 R II	Reduziereins. 3/8 x 1/4"	3.20
863	Umschaltknarre 4 1/2"	16.—
863 E**	kompl. Einsatzteil mit Drehknopf u. Federring	9.80
864	Gelenkgriff 6"	8.20
865	Schiebegriff 5"	3.20
866	Vierkantknebel 5"	5.20
867	Verlängerung 2"	2.90
868	Verlängerung 6"	3.70
869	Kardangelenk	6.20
870	biegs. Verlängerung 6"	4.90



**Steckschlüsselsätze
CHROM-VANADIUM**

880-881 mit Sechskant-Einsätzen

3/8" □



Metr. Maße

Bestell-Nr.	Inhalt	Verchromt Köpfe geschliffen
880	14 Sechskant-Einsätze 9 10 11 12 13 14 15 16 17 18 19 20 21 22 8811 8813 8814 8815 8816 8820 8821-3, 6, 12	117.40
881	wie 880, zusätzlich je 1 Einsatz 6, 7, 8	123.20

Amerik. Maße

880 A	1/4 — 3/4	104.80
--------------	-----------	---------------



**Steckschlüsselsätze
CHROM-VANADIUM**

880 Z-882 Z mit Zwölfkant-Einsätzen

3/8" □



Metr. Maße

880 Z	wie 880, jedoch Zwölfkant-Einsätze	119.—
881 Z	wie 880 Z, zusätzlich je 1 Sechskant-Einsatz 6, 7, 8	124.80

Amerik. Maße

881 AZ	3/8 — 7/8	112.20
882 AZ	1/4 — 7/8	116.—

Engl. Maße

880 WZ	1/8 — 1/2	102.40
---------------	-----------	---------------

Amerik. und engl. Maße

880 AWZ	3/8 — 7/8 A 1/8 — 1/2 W	128.80
----------------	----------------------------	---------------



**Steckschlüsselsätze
CHROM-VANADIUM**

883-884 mit Sechskant-Einsätzen

3/8" □



Metr. Maße

883	17 Sechskant-Einsätze 6 7 8 9 10 11 12 13 14 15 16 17 18 19 20 21 22 8813 8814 8821-6	65.80
884	wie 883, zusätzlich 8816	87.20

Amerik. Maße

883 A	1/4 — 3/4	47.40
884 A	1/4 — 3/4	68.60



**Steckschlüsselsätze
CHROM-VANADIUM**

883 Z-884 Z mit Zwölfkant-Einsätzen

3/8" □



Metr. Maße

Bestell-Nr.	Inhalt	Verchromt Köpfe geschliffen
883 Z	14 Zwölfkant-Einsätze 9 10 11 12 13 14 15 16 17 18 19 20 21 22 8813 8814 8821-6	61.60
884 Z	wie 883 Z, zusätzlich 8816	82.80

Amerik. Maße

883 AZ	3/8 — 15/16	57.60
884 AZ	3/8 — 15/16	78.80

Engl. Maße

883 WZ	1/8 — 1/2	45.—
884 WZ	1/8 — 1/2	66.20

Amerik. und engl. Maße

883 AWZ	3/8 — 7/8 A 1/8 — 1/2 W	60.80
884 AWZ	3/8 — 7/8 A 1/8 — 1/2 W	82.20



**Steckschlüsselsätze
CHROM-VANADIUM**

888 Z mit Sechskant- und Zwölfkant-Einsätzen

3/8" □

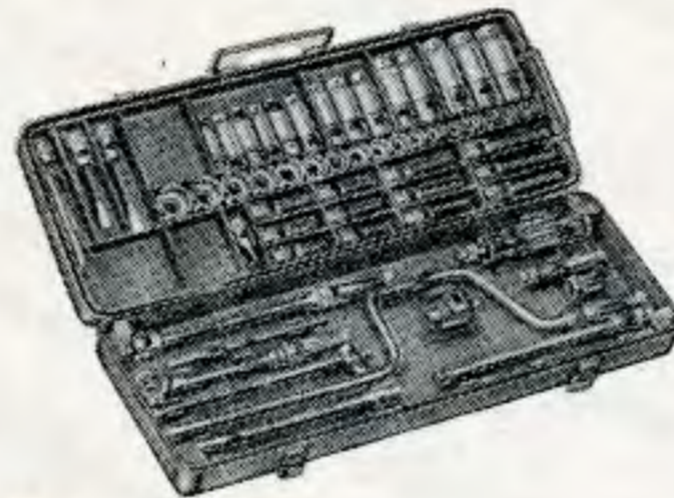

Metr. Maße

888 Z	3 Sechskant-Einsätze 6-8 14 Zwölfkant-Einsätze 9-22 14 Zwölfkant-Einsätze, extra tief, 9-22 9 Einsätze für Innen-Sechskant-Schrauben 3, 4, 5, 6, 7, 8, 9, 10, 12 3 Schraubenzieher-Einsätze, auswechselbar, 6, 8, 10 1 dto. fest, 17 3 dto. für Kreuzschlitzschrauben, auswechselbar, Gr. 2, 3, 4 8811 8812 8813 8814 8815 8816 8819 8820 8821-3, 6, 8, 12 8830 858 RI	300.—
--------------	--	--------------

Amerik. Maße

888 AZ	1/4 — 15/16	268.60
---------------	-------------	---------------

Engl. Maße

888 WZ	1/8 — 1/2	214.60
---------------	-----------	---------------



**Sechskant-Einsätze
CHROM-VANADIUM**

880

3/8" □



Metr. Maße

Bestell-Nr.	mm / Zoll	Verchromt Köpfe geschliffen
880-06	6	2.—
07	7	
08	8	
09	9	
10	10	
11	11	
12	12	
13	13	
14	14	
15	15	
16	16	
17	17	
18	18	
19	19	
20	20	
21	21	
22	22	

Amerik. Maße

880 A-08	1/4	2.—
10	5/16	
12	3/8	
14	7/16	
16	1/2	
18	9/16	
20	5/8	
22	11/16	
24	3/4	



**Zwölfkant-Einsätze
CHROM-VANADIUM**

880 Z

3/8" □



Metr. Maße

880 Z-09	9	2.10
10	10	
11	11	
12	12	
13	13	
14	14	
15	15	
16	16	
17	17	
18	18	
19	19	
20	20	
21	21	
22	22	

Amerik. Maße

880 AZ-11	11/32	2.10
12	3/8	
14	7/16	
16	1/2	
18	9/16	
19	19/32	
20	5/8	
22	11/16	
24	3/4	
25	25/32	
26	13/16	
28	7/8	
30	15/16	

Engl. Maße

880 WZ-04	1/8	2.10
06	3/16	
08	1/4	
10	5/16	
12	3/8	
14	7/16	
16	1/2	

Hazel Zwölfkant-Einsätze
CHROM-VANADIUM

880 TZ extra tief

3/8" □



Metr. Maße

Bestell-Nr.	mm / Zoll	Verchromt Köpfe geschliffen
880 TZ - 09	9	3.10
10	10	
11	11	
12	12	
13	13	3.30
14	14	3.60
15	15	3.80
16	16	4.—
17	17	4.20
18	18	4.50
19	19	4.70
20	20	4.70
21	21	4.70
22	22	4.70

Amerik. Maße

880 TAZ - 12	3/8	3.10
14	7/16	
16	1/2	3.30
18	9/16	3.60
19	19/32	3.80
20	5/8	4.—
22	11/16	4.20
24	3/4	4.50
26	13/16	4.70
28	7/8	4.70

Engl. Maße

880 TWZ - 04	1/8	3.10
06	3/16	
08	1/4	3.30
10	5/16	3.80
12	3/8	4.20
14	7/16	4.70
16	1/2	4.70

Hazel Einsätze für Innen-
sechskantschrauben
880 CHROM-VANADIUM

3/8" □



Metr. Maße auswechselbar

8801 - 03	3	3.30
04	4	3.50
05	5	
06	6	3.80
07	7	
08	8	4.—
09	9	4.20
10	10	4.50
12	12	5.—

Amerik. Maße

8801 A - 04	1/8	3.30
05	5/32	3.50
06	3/16	
07	7/32	3.80
08	1/4	
10	5/16	4.—
12	3/8	4.20

Hazel Schraubenzieher-
Einsätze
880 CHROM-VANADIUM

3/8" □



auswechselbar

Bestell-Nr.	mm	Verchromt Köpfe geschliffen
8803 - 6	6	4.70
8	8	5.20
10	10	5.40
fest		
8804 - 17	17	2.20

Hazel Kreuzschlitzschraub-
zieher-Einsätze
880 CHROM-VANADIUM

3/8" □



auswechselbar

8806 - 2	2	5.20
3	3	5.40
4	4	5.80

Hazel Betätigungswerkzeuge
CHROM-VANADIUM

880

3/8" □



Bestell-Nr.	Bezeichnung	Verchromt Köpfe geschliffen
8811	Schwungwinde 18"	7.10
8812	Steckgriff 5"	6.50
8813	Stecker 6"	1.60
8814	Gelenkgriff 9 1/2"	10.30
8815	Schiebegriff 8"	5.20
8816	Umschaltknarre 40 Zähne, 8"	21.30
8816 E	kompl. Einsatzteil mit Drehknopf und Federring	13.80
8819	Aufsteckknarre 20 Zähne	19.—
8820	Kardangelen	7.30
8821 - 3	Verlängerung 3"	4.—
6	Verlängerung 6"	4.40
8	Verlängerung 8"	5.10
12	Verlängerung 12"	5.70
20	Verlängerung 20"	7.40
8830	biegs. Verlängerung 8"	6.30

Hazel Steckschlüsselsätze
CHROM-VANADIUM

900-

906

1/2" □

mit Sechskant-Einsätzen



Metr. Maße

Bestell-Nr.	Inhalt	Verchromt Köpfe geschliffen
900	18 Sechskant-Einsätze 12 13 14 15 16 17 18 19 20 21 22 23 24 26 27 28 30 32 911, 915, 916, 917, 918, 920, 980-13	106.20
901	wie 900, zusätzlich 914/15"	119.80
904	wie 900, zusätzlich je 1 Einsatz 10, 11	110.40
905	wie 904, zusätzlich 914/15"	123.80
906	13 Sechskant-Einsätze 10 11 12 13 14 15 17 19 22 24 27 30 32 911, 915, 916, 918, 920	84.80

Hazel Steckschlüsselsätze
CHROM-VANADIUM

900 Z-
906 Z

1/2" □

mit Zwölfkant-Einsätzen



Metr. Maße

900 Z	18 Zwölfkant-Einsätze 12 13 14 15 16 17 18 19 20 21 22 23 24 26 27 28 30 32 911, 915, 916, 917, 918, 920, 980-13	113.40
901 Z	wie 900 Z, zusätzlich 914/15"	126.80
904 Z	wie 900 Z, zusätzlich je 1 Einsatz 10, 11	117.80
905 Z	wie 904 Z, zusätzlich 914/15"	131.20
906 Z	13 Zwölfkant-Einsätze 10 11 12 13 14 15 17 19 22 24 27 30 32 911, 915, 916, 918, 920	89.20

Amerik. Maße

900 AZ	3/8 — 1 1/4	112.60
901 AZ	3/8 — 1 1/4	126.—
906 AZ	3/8 — 1 1/4	86.—

Engl. Maße

900 WZ	3/16 — 3/4	88.—
901 WZ	3/16 — 3/4	101.60

Amerik. und engl. Maße

900 AWZ	1/2 — 1 1/16 A 3/16 — 5/8 W	110.—
901 AWZ	1/2 — 1 1/16 A 3/16 — 5/8 W	123.40

Metr., amerik. und engl. Maße

900 AWM	10-22, 7/16-1 A 3/16 — 3/4 W	156.—
901 AWM	10-22, 7/16-1 A 3/16 — 3/4 W	169.60



Steckschlüsselsätze CHROM-VANADIUM

930-
944

mit Sechskant-Einsätzen

1/2" □



Metr. Maße

Bestell-Nr.	Inhalt	Verchromt Köpfe geschliffen
930	18 Sechskant-Einsätze 12 13 14 15 16 17 18 19 20 21 22 23 24 26 27 28 30 32 916, 918	82.—
934	wie 930, zusätzlich je 1 Einsatz 10, 11	86.—
940	11 Sechskant-Einsätze 12 13 14 15 16 17 18 19 20 21 22 916, 918	54.60
944	wie 940, zusätzlich je 1 Einsatz 10, 11	58.80



Steckschlüsselsätze CHROM-VANADIUM

930Z-
944Z

mit Zwölfkant-Einsätzen

1/2" □



Metr. Maße

930 Z	wie 930, jedoch mit Zwölfkant-Einsätzen	89.—
934 Z	wie 934, jedoch mit Zwölfkant-Einsätzen	93.60
940 Z	wie 940, jedoch mit Zwölfkant-Einsätzen	58.—
944 Z	wie 944, jedoch mit Zwölfkant-Einsätzen	62.60
Amerik. Maße		
930 AZ	3/8 — 1 1/4	88.40
940 AZ	3/8 — 7/8	57.20
Engl. Maße		
940 WZ	3/16 — 3/4	61.60
Amerik. und engl. Maße		
930 AWZ	1/2 — 1 1/16A 3/16 — 5/8 W	85.60



Steckschlüsselsätze CHROM-VANADIUM

931-
945

mit Sechskant-Einsätzen

1/2" □

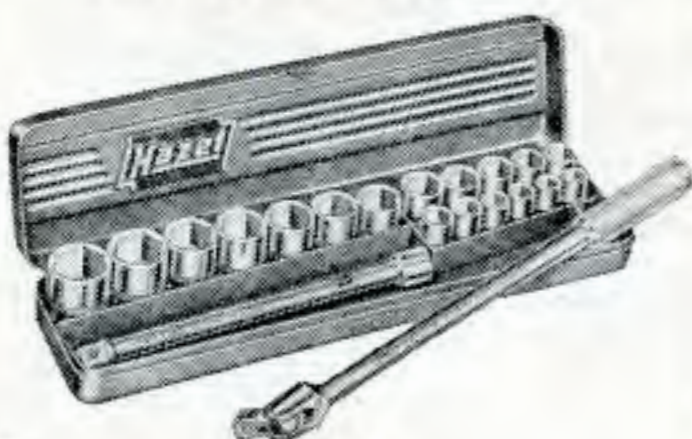

Metr. Maße

931	18 Sechskant-Einsätze 12 13 14 15 16 17 18 19 20 21 22 23 24 26 27 28 30 32 914/15", 918	78.20
935	wie 931, zusätzlich je 1 Einsatz 10, 11	82.20
941	11 Sechskant-Einsätze 12 13 14 15 16 17 18 19 20 21 22 914/15", 918	50.80
945	wie 941, zusätzlich je 1 Einsatz 10, 11	55.—



Steckschlüsselsätze CHROM-VANADIUM

931Z-
945Z

mit Zwölfkant-Einsätzen

1/2" □

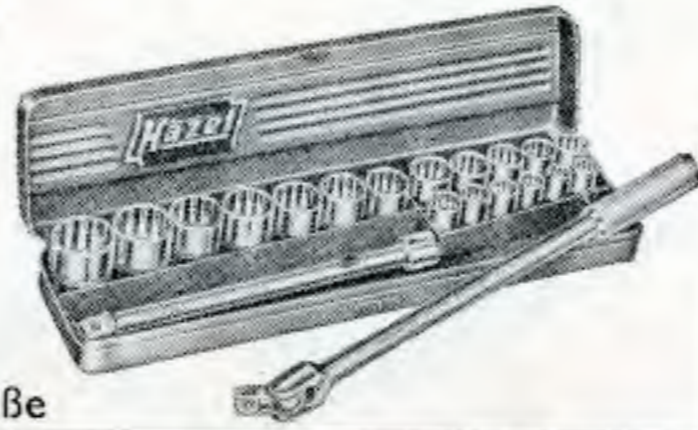

Metr. Maße

Bestell-Nr.	Inhalt	Verchromt Köpfe geschliffen
931 Z	wie 931, jedoch mit Zwölfkant-Einsätzen	85.20
935 Z	wie 935, jedoch mit Zwölfkant-Einsätzen	89.80
941 Z	wie 941, jedoch mit Zwölfkant-Einsätzen	54.20
945 Z	wie 945, jedoch mit Zwölfkant-Einsätzen	58.80
Amerik. Maße		
931 AZ	3/8 — 1 1/4	84.60
941 AZ	3/8 — 7/8	53.40
Engl. Maße		
941 WZ	3/16 — 3/4	57.80
Amerik. und engl. Maße		
931 AWZ	1/2 — 1 1/16A 3/16 — 5/8 W	81.80



Steckschlüsselsätze CHROM-VANADIUM

950Z

mit Zwölfkant-Einsätzen

1/2" □



Metr. Maße

950 Z	6 Zwölfkant-Einsätze 13 14 16 17 19 22 913	21.40
Amerik. Maße		
950 AZ	7/16 — 3/4	20.40
Engl. Maße		
950 WZ	3/16 — 1/2	21.80



Sechskant-Einsätze CHROM-VANADIUM

900

1/2" □



Metr. Maße

Bestell-Nr.	mm	Verchromt Köpfe geschliffen
900 - 10	10	
11	11	2.10
12	12	
13	13	
14	14	
15	15	2.20
16	16	
17	17	
18	18	2.70
19	19	
20	20	
21	21	2.80
22	22	
23	23	
24	24	3.10
25	25	
26	26	
27	27	
28	28	3.90
29	29	
30	30	
32	32	4.20



Zwölfkant-Einsätze CHROM-VANADIUM

900 Z

1/2" □



Metr. Maße

Bestell-Nr.	mm / Zoll	Verchromt Köpfe geschliffen
900 Z - 10	10	
11	11	2.30
12	12	
13	13	
14	14	
15	15	2.40
16	16	
17	17	
18	18	3.—
19	19	
20	20	
21	21	3.20
22	22	
23	23	
24	24	3.60
25	25	
26	26	
27	27	
28	28	4.50
29	29	
30	30	
32	32	4.70
33	33	

Amerik. Maße

900 AZ - 12	3/8	2.30
14	7/16	
16	1/2	
18	9/16	2.40
19	19/32	
20	5/8	
22	11/16	3.—
24	3/4	
25	25/32	3.20
26	13/16	
28	7/8	
30	15/16	3.60
31	31/32	
32	1	
34	1 1/16	4.50
36	1 1/8	
38	1 3/16	
40	1 1/4	4.70

Engl. Maße

900 WZ - 06	3/16	2.30
08	1/4	
10	5/16	2.40
12	3/8	3.—
14	7/16	3.20
16	1/2	3.60
18	9/16	
20	5/8	4.50
22	11/16	
24	3/4	4.70



Zwölfkant-Einsätze CHROM-VANADIUM

900 TZ

extra tief

1/2" □



Metr. Maße

900 TZ - 21	21	5.30
26	26	5.80
30	30	6.90



Betätigungswerkzeuge CHROM-VANADIUM

911-
980

1/2" □

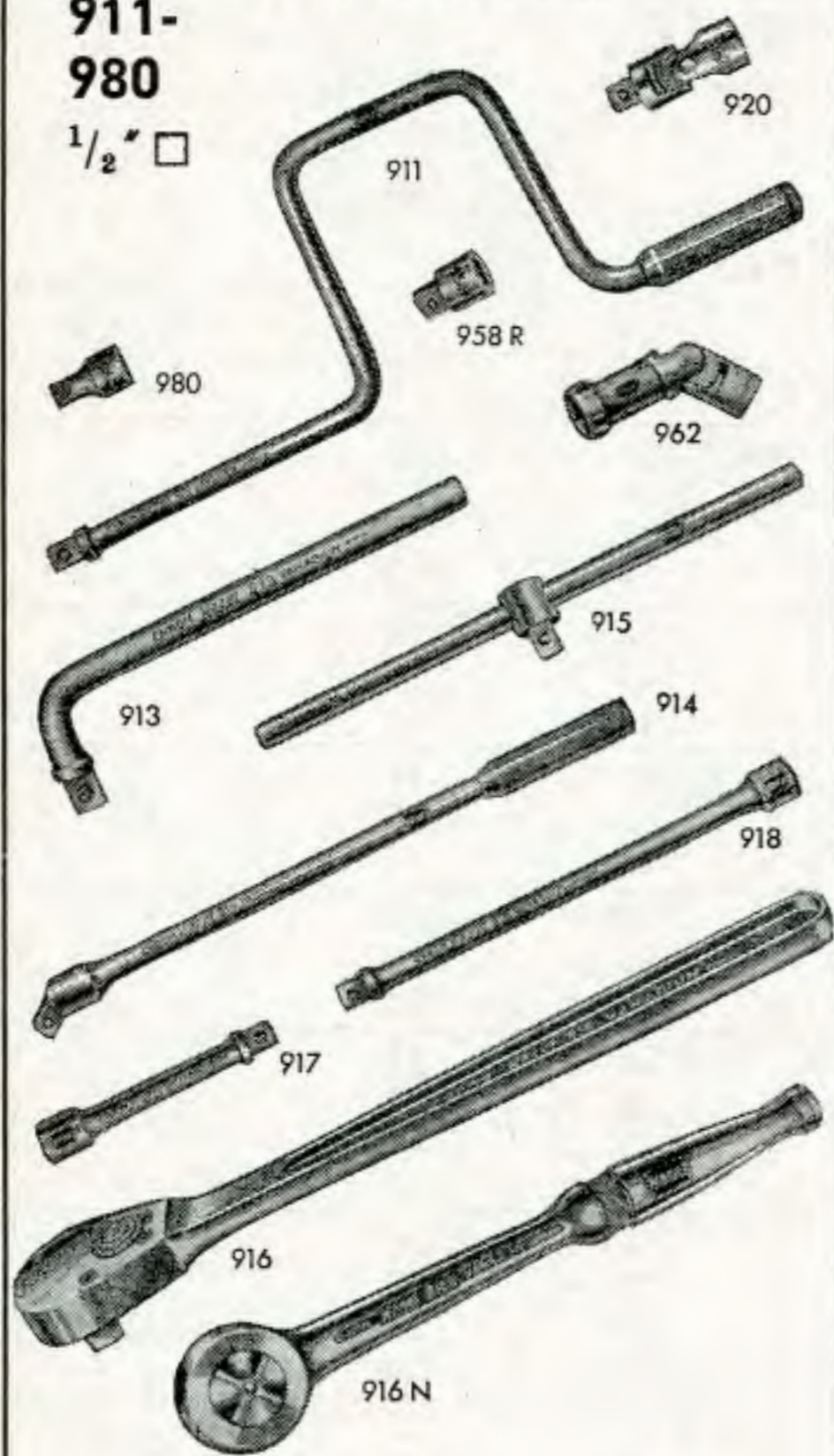

Bestell-Nr.	Bezeichnung	Verchromt Köpfe geschliffen
911	Schwunggriff 16 1/2"	7.90
913	Winkelgriff 7 1/2"	3.—
914 - 15	Winkelgriff mit Gelenk 15"	13.50
914 - 18	Winkelgriff mit Gelenk 18"	15.—
915	T-Griff mit verschiebbarem Gleitstück 12"	6.—
916	Umschaltknarre 28 Zähne, serienmäßig in Sortimenten, 12"	17.60
916 N	Umschaltknarre 50 Zähne, nur auf Wunsch in Sortimenten, 10"	28.80
916 NE**	kompl. Einsatzteil mit Drehknopf und Federring	17.90
917	Verlängerung 5"	3.—
918	Verlängerung 10"	4.—
920	Universalgelenk 2 1/2" mit Innen-Arretierung	7.10
958 RI	Reduzier-einsatz 1/2" □ massiv 3/8" □ hohl	3.40
958 RII	Reduzier-einsatz 3/8" □ massiv 1/2" □ hohl	4.10
962	Zündkerzenschlüssel-Einsatz mit Kardan-gelenk, 21 mm	9.30
980 - 13	Schraubenzieher-Eins. Klingenbreite 13 mm Klingenstärke 2 mm	2.—
980 - 19	Schraubenzieher-Eins. Klingenbreite 19 mm Klingenstärke 3 mm	2.30
980 - 24	Schraubenzieher-Eins. Klingenbreite 24 mm Klingenstärke 4 mm	2.40



Sechskant-Einsätze für Inbusschrauben CHROM-VANADIUM

985

1/2" □



Metr. Maße

Bestell-Nr.	mm	Verchromt Köpfe geschliffen
985 - 05	5	3.70
06	6	3.70
08	8	4.10
10	10	4.50
12	12	5.—
14	14	5.20
17	17	5.60
19	19	6.—



985 K

1/2" □



Satz mit Betätigungswerkzeugen im Kasten

Bestell-Nr.	Inhalt	Verchromt Köpfe geschliffen
985 K	8 Einsätze für Inbusschrauben 5 6 8 10 12 14 17 19 915, 916, 917, 918	76.40



Steckschlüsselsätze CHROM-VANADIUM

1000-
1011

3/4" □

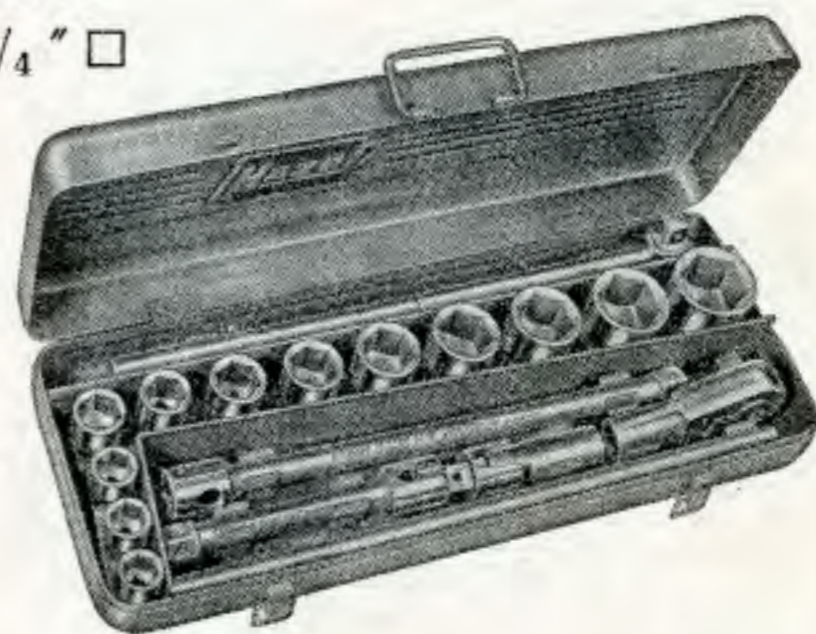

Metr. Maße

Bestell-Nr.	Inhalt	Verchromt Köpfe geschliffen
1000	10 Sechskant-Einsätze 22 24 27 30 32 36 38 41 46 50 1014, 1015, 1016, 1017, 1018, 1020	198.40
1002	wie 1000, zusätzlich je 1 Einsatz 55, 60	246.80
1010	10 Sechskant-Einsätze 22 24 27 30 32 36 38 41 46 50 1015, 1017, 1018	130.40
1011	10 Sechskant-Einsätze 22 24 27 30 32 36 38 41 46 50 1014, 1016, 1017, 1018	158.—



Steckschlüsselsätze CHROM-VANADIUM

1000 Z-
1012 Z

3/4" □



Metr. Maße

1000 Z	wie 1000, jedoch mit Zwölfkant-Einsätzen	202.60
1002 Z	wie 1002, jedoch mit Zwölfkant-Einsätzen (55 u. 60 = Sechskant)	252.—
1010 Z	wie 1010, jedoch mit Zwölfkant-Einsätzen	134.60
1011 Z	wie 1011, jedoch mit Zwölfkant-Einsätzen	161.20
1012 Z	9 Zwölfkant-Einsätze 23 26 29 32 35 38 42 46 50 1014, 1015, 1016, 1017, 1018	182.—

Amerik. Maße

1000 AZ	7/8 — 2	249.—
1010 AZ	7/8 — 2	181.—
1011 AZ	7/8 — 2	208.80
1012 AZ	1 1/16 — 2	186.40

Engl. Maße

1000 WZ	1/2 — 1 1/8	191.—
1010 WZ	1/2 — 1 1/8	123.—
1011 WZ	1/2 — 1 1/8	150.—



**Sechskant-Einsätze
CHROM-VANADIUM**
mit Stiftsicherung

1000

3/4" □



Metr. Maße

Bestell-Nr.	mm/Zoll	Verchromt Köpfe geschliffen
1000 - 22	22	3.80
24	24	4.10
27	27	5.—
30	30	6.30
32	32	6.70
36	36	7.30
38	38	7.70
41	41	9.—
46	46	9.90
50	50	11.20
55	55	21.—
60	60	27.20



**Betätigungswerkzeuge
CHROM-VANADIUM**

1000

3/4" □

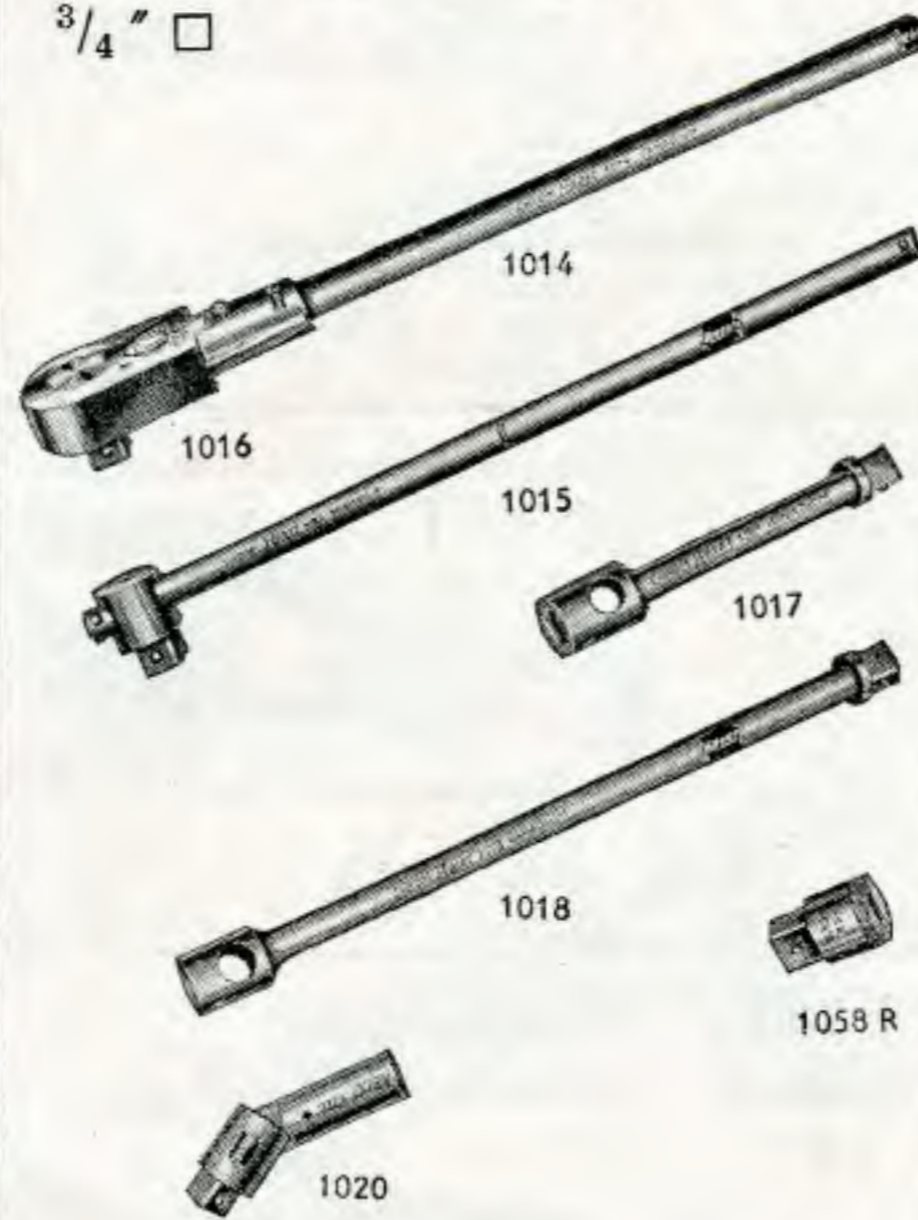

Bestell-Nr.	Bezeichnung	Verchromt Köpfe geschliffen
1014	Stecker 20"	10.30
1015	Schiebegriff 20"	17.—
1016	Knarrenkopf 6"	34.40
1017	Verlängerung 8 1/2"	8.20
1018	Verlängerung 17"	10.60
1020	Gelenkstück 5"	15.70
1058 RI	Reduzier-einsatz 1/2" □ massiv 3/4" □ hohl	5.20
1058 RII	Reduzier-einsatz 3/4" □ massiv 1/2" □ hohl	4.50



**Werkzeugausrüstungen
CHROM-VANADIUM**

1100

für Traktoren



in hausfarbenen HAZET-Metallkästen

Bestell-Nr.	Inhalt	Verchromt
1100	35 teilig	241.—
1100 A	35 teilig	241.—



**Werkzeugausrüstungen
CHROM-VANADIUM**

1100-1

für Traktoren



in hausfarbenen HAZET-Metallkästen

1100 - 1	74 teilig	591.—
1100 - 1 A	74 teilig	586.—
1100 - 1 W	70 teilig	591.—



**Werkzeugsatz
CHROM-VANADIUM**

1102

für FORDSON-Traktoren
in Plastic-Tasche

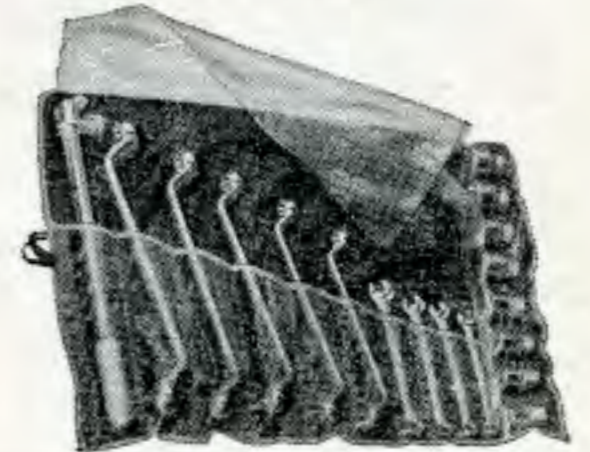

Bestell-Nr.	Inhalt	Verchromt
1102 A	18 teilig	87.—



**Werkzeugsätze
CHROM-VANADIUM**

1130-

1135

kombiniert



in hausfarbenen HAZET-Metallkästen

1130 M	49 teilig	243.—
1130 A	39 teilig	200.—
1130 W	31 teilig	182.—
1135 M	34 teilig	160.—
1135 A	29 teilig	155.—
1135 W	24 teilig	138.—



**Werkzeugsatz
CHROM-VANADIUM**

1140

kombiniert

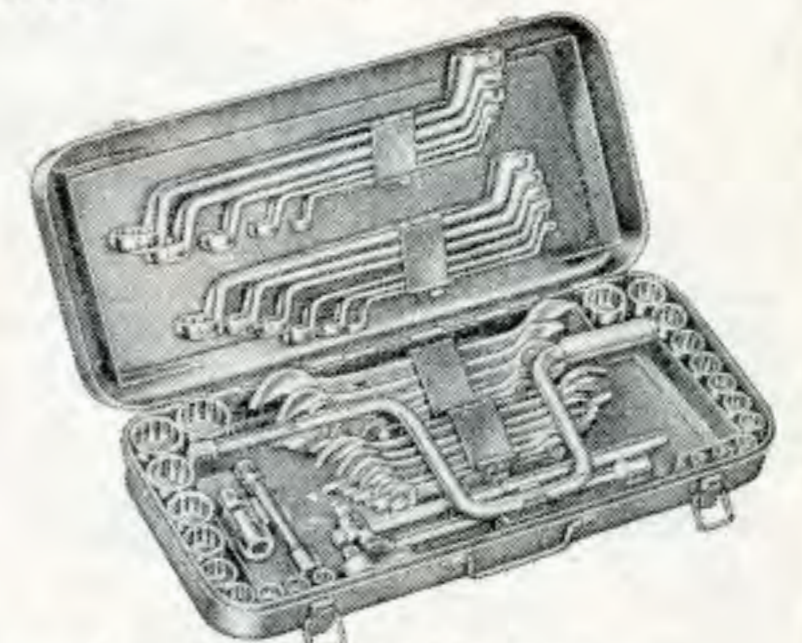

im hausfarbenen HAZET-Metallkasten

1140 AW	49 teilig	254.—
---------	-----------	-------



**Werkzeugsatz
CHROM-VANADIUM**

1150

kombiniert



im hausfarbenen HAZET-Metallkasten

1150	32 teilig	199.—
------	-----------	-------



**Zwölfkant-Einsätze
CHROM-VANADIUM**

1000 Z

3/4" □



Metr. Maße

Bestell-Nr.	mm/Zoll	Verchromt Köpfe geschliffen
1000 Z - 22	22	3.90
23	23	3.90
24	24	4.30
25	25	4.30
26	26	4.70
27	27	5.30
28	28	5.30
29	29	6.90
30	30	6.90
32	32	7.30
33	33	7.30
35	35	7.80
36	36	7.80
38	38	8.10
41	41	9.50
42	42	9.50
46	46	10.70
50	50	11.60

Amerik. Maße

1000 AZ - 28	7/8	3.90
30	15/16	4.30
31	31/32	4.30
32	1	4.30
34	1 1/16	5.30
36	1 1/8	6.90
38	1 3/16	6.90
40	1 1/4	7.30
42	1 5/16	7.30
44	1 3/8	7.80
46	1 7/16	7.80
48	1 1/2	8.10
50	1 9/16	8.50
52	1 5/8	9.50
54	1 11/16	9.50
56	1 3/4	9.50
58	1 13/16	10.70
60	1 7/8	10.70
64	2	11.60

Engl. Maße

1000WZ - 16	1/2	3.90
18	9/16	4.30
20	5/8	5.30
22	11/16	6.90
24	3/4	7.30
26	13/16	7.80
28	7/8	8.10
32	1	9.50
36	1 1/8	10.70



**Kraftseitenschneider
SPEZIALSTAHL**

1801



Bestell-Nr.	mm/Zoll		Hochglanz verchromt
1801 - 0	130	5	9.20
1	145	6	9.50
2	165	6 ¹ / ₂	11.40
3	200	8	14.60

mit Handschutz-Isolierung
10000 Volt

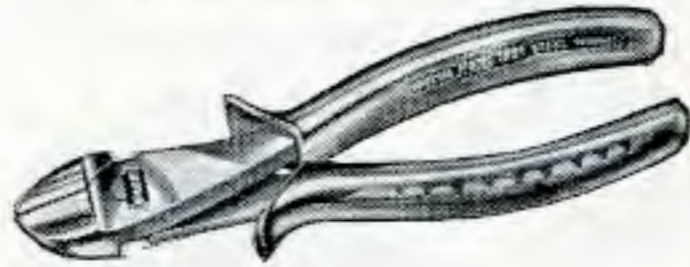

1801 - 00	130	5	11.40
11	145	6	12.10
22	165	6 ¹ / ₂	13.80
33	200	8	17.—



**Kraftseitenschneider
CHROM-VANADIUM**

1802



1802 - 1	145	6	11.40
2	170	7	12.70
3	200	8	17.—

mit Handschutz-Isolierung
10000 Volt



1802 - 11	145	6	13.80
22	170	7	15.30
33	200	8	20.20



**Seitenschneider
SPEZIALSTAHL
schwedische Form**

1803



1803 - 0	115	4 ¹ / ₂	7.40
1	130	5	8.40
2	145	6	9.50
3	160	6 ¹ / ₂	10.50

mit Handschutz-Isolierung
10000 Volt



1803 - 00	115	4 ¹ / ₂	9.60
11	130	5	10.50
22	145	6	12.—
33	160	6 ¹ / ₂	13.40



**Kraftvorschneider
SPEZIALSTAHL**

1807



Bestell-Nr.	mm/Zoll		Hochglanz verchromt
1807 - 0	130	5	10.50
1	160	6 ¹ / ₂	12.70
2	200	8	17.—

mit Handschutz-Isolierung
10000 Volt

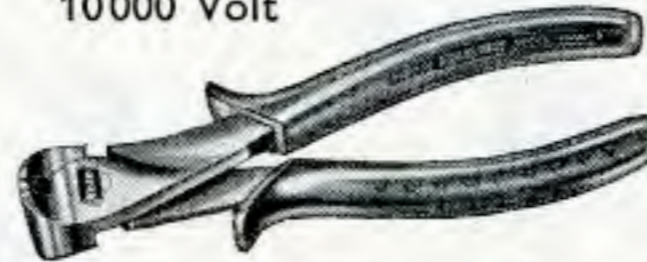

1807 - 00	130	5	12.70
11	160	6 ¹ / ₂	14.80
22	200	8	19.80



**Flachzangen
SPEZIALSTAHL**

1811



1811 - 1	120	5	5.60
2	140	5 ¹ / ₂	6.20
3	160	6 ¹ / ₂	6.80
4	180	7	7.80

mit Handschutz-Isolierung
10000 Volt

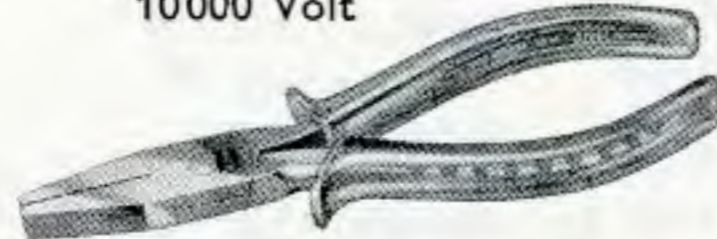

1811 - 11	120	5	7.90
22	140	5 ¹ / ₂	8.80
33	160	6 ¹ / ₂	9.50
44	180	7	10.50



**Rundzangen
SPEZIALSTAHL**

1821



1821 - 1	120	5	5.60
2	140	5 ¹ / ₂	6.20
3	160	6 ¹ / ₂	6.80
4	180	7	7.80

mit Handschutz-Isolierung
10000 Volt

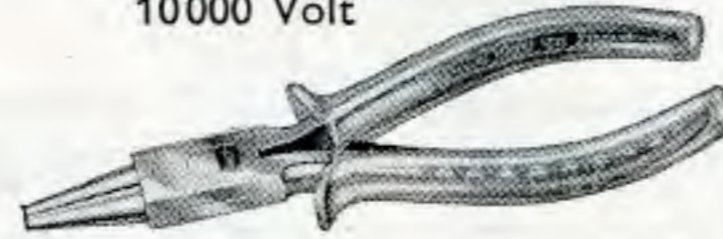

1821 - 11	120	5	7.90
22	140	5 ¹ / ₂	8.80
33	160	6 ¹ / ₂	9.50
44	180	7	10.50



**Langbeckzangen
SPEZIALSTAHL**

1815



1815 - 1	130	5	6.40
2	160	6 ¹ / ₂	7.30

mit Handschutz-Isolierung
10000 Volt



1815 - 11	130	5	8.60
22	160	6 ¹ / ₂	9.90



**Langbeckzangen
SPEZIALSTAHL**

1825

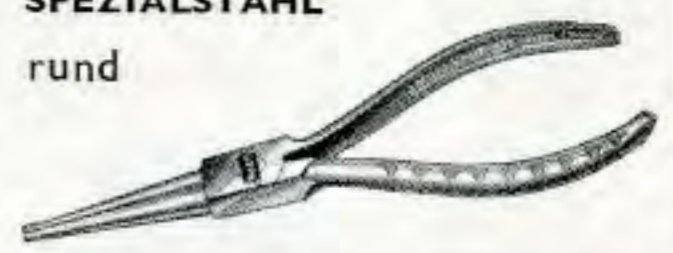

Bestell-Nr.	mm/Zoll		Hochglanz verchromt
1825 - 1	130	5	6.40
2	160	6 ¹ / ₂	7.30

mit Handschutz-Isolierung
10000 Volt



1825 - 11	130	5	8.60
22	160	6 ¹ / ₂	9.90



**Long-Grip-Zangen
CHROM-VANADIUM**

1841



mit geraden ovalspitzen Backen

1841 a - 1	145	5 ¹ / ₂	8.40
2	170	7	9.20
3	210	8	11.20

stumpfwinklig gebogen (35°)

1841 b - 3	210	8	12.—
------------	-----	---	------

rechtwinklig gebogen

1841 c - 3	210	8	12.—
------------	-----	---	------

mit Handschutz-Isolierung
10000 Volt

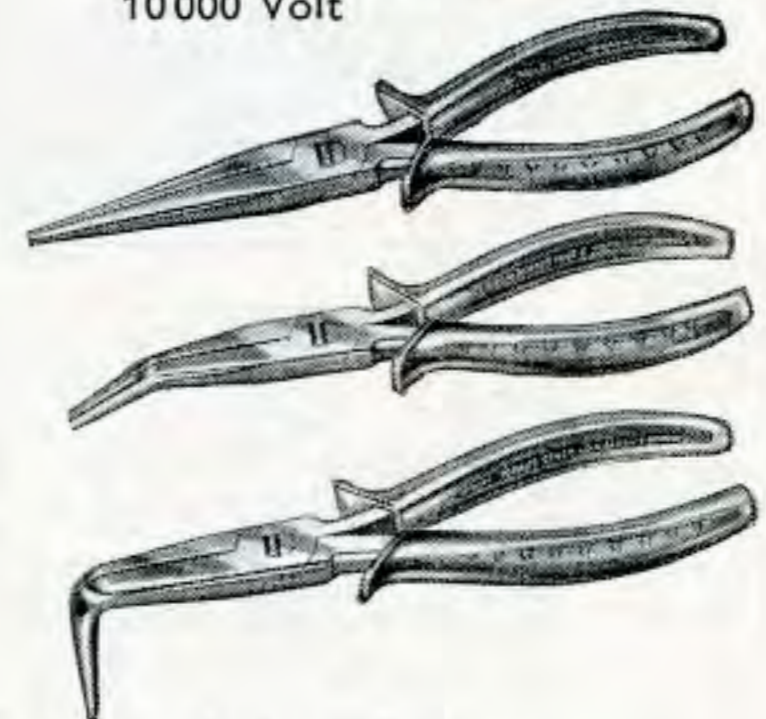

mit geraden ovalspitzen Backen

1841 a - 11	145	5 ¹ / ₂	11.20
22	170	7	12.30
33	210	8	14.20

stumpfwinklig gebogen (35°)

1841 b - 33	210	8	14.90
-------------	-----	---	-------

rechtwinklig gebogen

1841 c - 33	210	8	14.90
-------------	-----	---	-------



**Splintenausziehzange
CHROM-VANADIUM**

1842



1842	170	7	12.80
------	-----	---	-------



Spezialzangen
CHROM-VANADIUM
für Seegersicherungen

1846

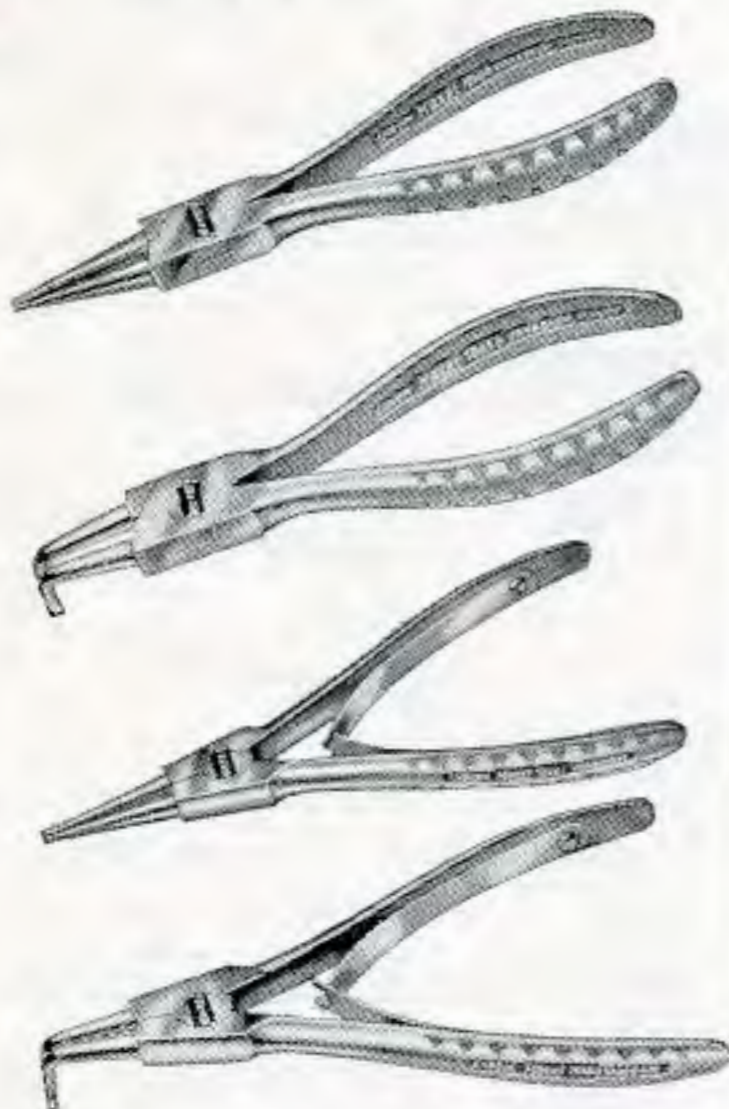

gerade - für Innensicherungen

Bestell-Nr.	mm/Zoll	Hochglanz verchromt
1846 a - 1	130 5	9.60
2	170 7	11.20
3	220 8 1/2	15.—

abgewinkelt - für Innensicherungen

1846 b - 1	130 5	11.—
2	170 7	12.50
3	220 8 1/2	15.90

gerade - für Außensicherungen

1846 c - 1	130 5	10.30
2	170 7	11.40
3	220 8 1/2	14.80

abgewinkelt - für Außensicherungen

1846 d - 1	130 5	11.—
2	170 7	12.70
3	220 8 1/2	15.90



**Batterie- und
Mutternzange**
CHROM-VANADIUM

1848



1848	200 8	9.60
------	-------	------



Kombinationszangen
SPEZIALSTAHL

1850

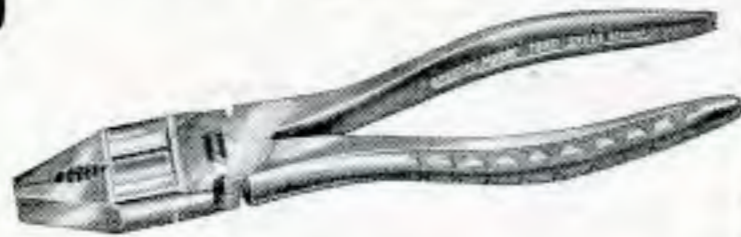

Bestell-Nr.	mm/Zoll	Hochglanz verchromt	Ver- chromt
1850 - 1	120 4 1/2	6.40	5.80
2	160 6	6.80	6.20
3	180 7	7.70	6.70
4	210 8	9.—	8.—

mit Handschutz-Isolierung
10000 Volt



1850 - 11	120 4 1/2	8.80	8.20
22	160 6	9.20	8.60
33	180 7	11.—	9.60
44	210 8	12.—	11.—



**Universal-
Figureschere**
CHROM-VANADIUM
mit Feder

1852

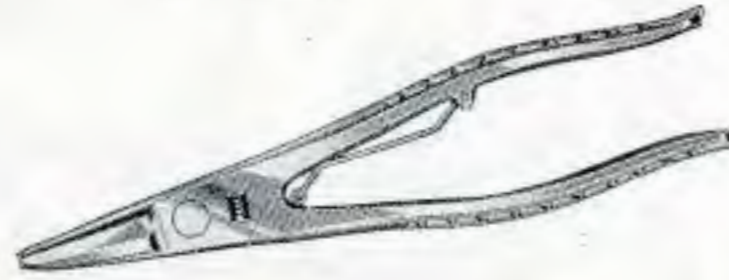

Bestell-Nr.	mm/Zoll	Hochglanz verchromt	Ver- chromt
1852	210 8	16.60	15.10



Kombinationszangen
CHROM-VANADIUM
neues Modell

1855



Bestell-Nr.	mm/Zoll	Hochglanz verchromt
1855 - 1	160 6	12.—
2	180 7	12.70
3	210 8	14.60

mit Handschutz-Isolierung
10000 Volt

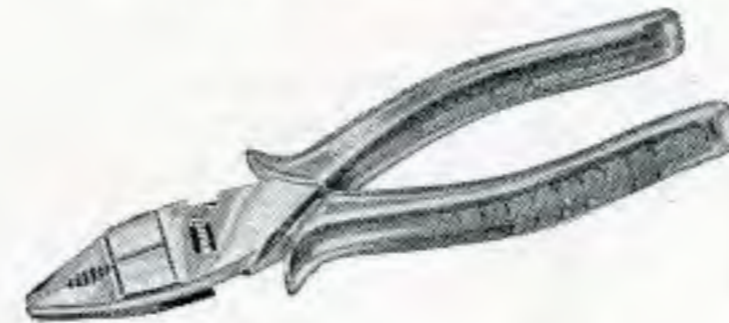

1855 - 11	160 6	14.20
22	180 7	15.50
33	210 8	17.40



**Dekorations- und
Verkaufstafel**

1800

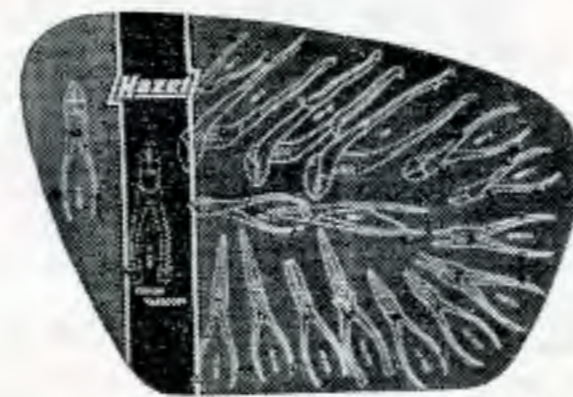

Bestell-Nr.	Sortiment	Preis
DV 1800 - 1	je 2 Zangen: 759 760 - 1 760 - 3 760 - 33 1801 - 2 1803 - 2 1807 - 1 1841 a - 3 1841 b - 3 1841 c - 3 1841 b - 33 1846 a - 2 1846 b - 2 1846 c - 2 1846 d - 2 1850 - 3 1850 - 33 1852 = 36teilig	412.—



Ausbeulwerkzeuge
SPEZIALSTAHL

1900

1905



Sortimente
in hausfarbenen HAZET-Metallkästen

Bestell-Nr.	Inhalt	Preis
1900	7teilig	112.40
1905	10teilig	189.—



Ausbeulwerkzeuge
SPEZIALSTAHL

1910



1910 K

1910 T

Sortimente
in hausfarbenen HAZET-Metallkästen

1910 K	24teilig	317.80
1910 KA	24teilig	317.80
1910 KW	24teilig	320.40

Sortiment
auf hausfarbener HAZET-Metallwandtafel

1910 T	15teilig	270.—
--------	----------	-------



Ausbeulwerkzeuge
SPEZIALSTAHL

1911-

1924



Bestell-Nr.	Bezeichnung	Preis
1911	Handfaust 140 x 55	16.60
1912	dto. 80 x 70/100 x 45	16.60
1913	dto. 60 x 70	16.60
1914	dto. 65 x 25/50 x 8	11.20
1915	dto. 75 x 6/45 x 25	21.20
1916	dto. 70 x 60	12.50
1917	dto. 70 x 60	12.70
1918	dto. 110 x 65	12.50
1919	dto. 115 x 55	11.40
1920	dto. 70 x 50/60 x 45	17.70
1921	dto. 80 x 60	11.40
1922	dto. 55 mm ø	11.40
1923	dto. 110 x 60	19.60
1924	dto., gebogen	36.20



Ausbeulwerkzeuge SPEZIALSTAHL

1926-
1934

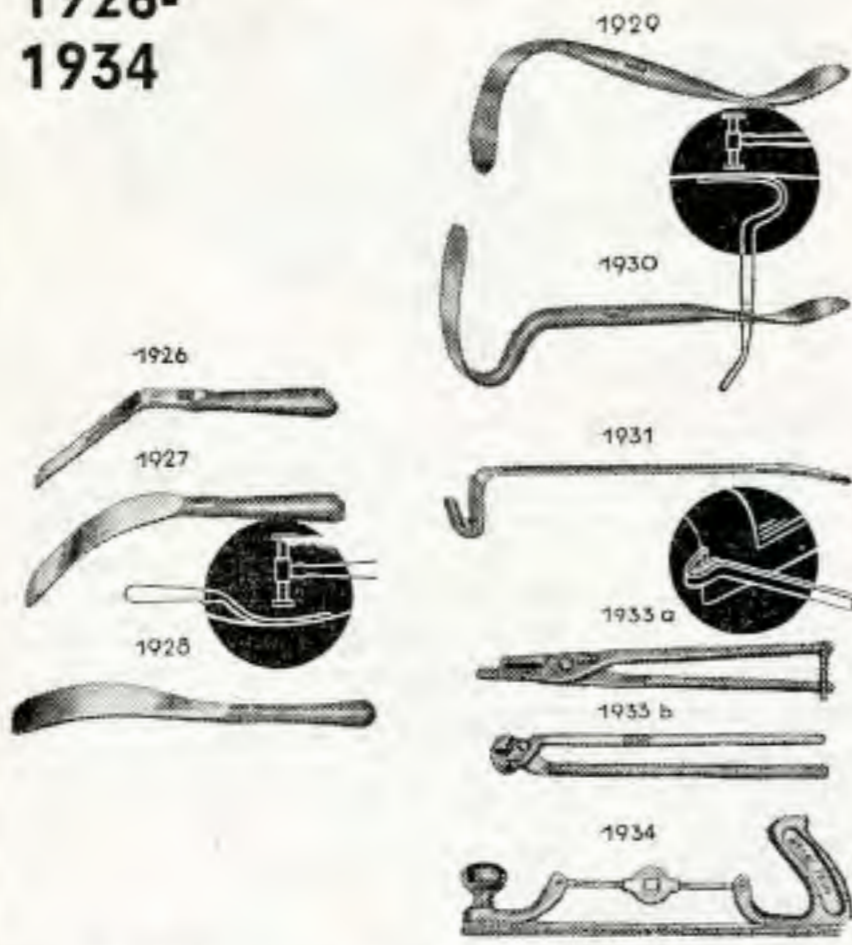

Bestell-Nr.	Bezeichnung	Preis
1926	Löffeleisen 290 mm	9.90
1927	dto. 310 mm	12.70
1928	dto. 390 mm	16.60
1929	Ausbeul-Hebeleisen, gekröpft u. geschweift	21.30
1930	dto., stark gekröpft und doppelt geschweift	25.20
1931	Biegeisen mit Ledereinsatz	8.80
1933 a	Kotflügel-Biegezange	6.90
1933 b	Bördelzange	6.30
1934	Karosserie-Feilenhalter, verstellb., m. Feilenblatt	27.90
1934 a	Feilenblatt, grob	9.60



Ausbeulwerkzeuge SPEZIALSTAHL

1935-
1943

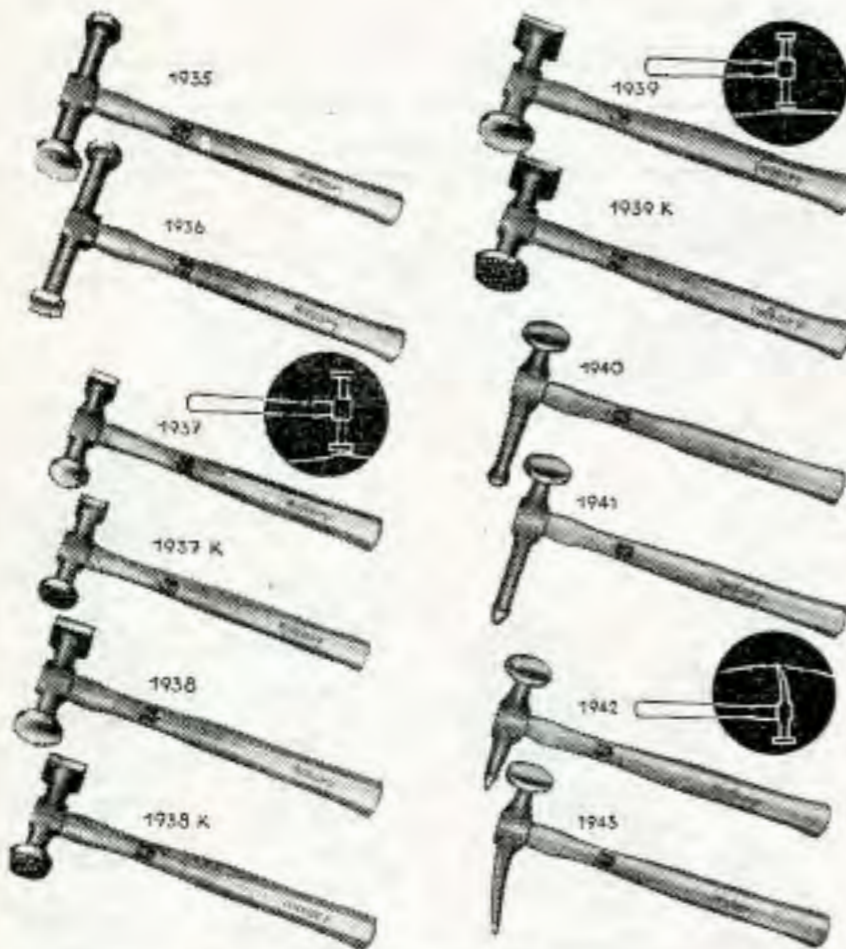

1935	Ausbeul- u. Schlichthammer, 150 mm	11.20
1936	Spann- u. Ausschlichthammer, 165 mm	11.20
1937	Spann- und Schlichthammer, 100 mm	9.60
1937 K	dto., jedoch die runde Bahn kariert gefräst	12.70
1938	Spann- und Schlichthammer, 105 mm	11.20
1938 K	dto., jedoch die runde Bahn kariert gefräst	13.90
1939	Spann- und Schlichthammer, 110 mm	12.70
1939 K	dto., jedoch die runde Bahn kariert gefräst	15.30
1940	Schlicht- und Treibhammer, 160 mm	11.20
1941	dto., jedoch eichel-förmige Bahn	11.20
1942	Schlicht- und Spitzhammer, 130 mm	11.20
1943	Schlicht- und Pinnhammer, 160 mm	12.50



Ausbeulwerkzeuge SPEZIALSTAHL

1944-
1948

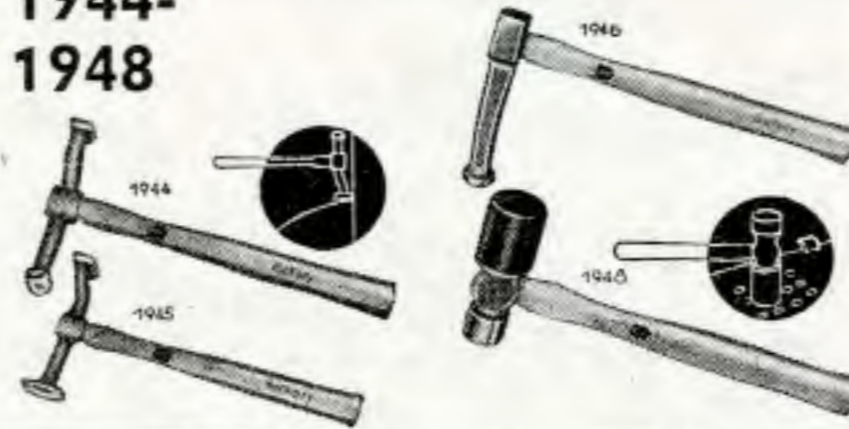

Bestell-Nr.	Bezeichnung	Preis
1944	Schlicht- und Schweifhammer, 150 mm	12.70
1945	dto., jedoch gekreuzt	12.70
1946	Tiefhammer, 175 mm	10.50
1948	Gummi- und Handhammer, kombiniert	18.10



Plastic-Hämmer mit auswechselbaren Einsätzen

1950



Bestell-Nr.	mm	Preis
1950 - 1	22∅	4.70
2	27∅	5.60
3	32∅	7.40
4	35∅	8.80
5	40∅	11.40
6	50∅	16.30
7	60∅	22.40

lose Einsätze

Bestell-Nr.	mm	Preis per Paar
1950 - 22	22∅	1.90
27	27∅	2.60
32	32∅	3.40
35	35∅	4.90
40	40∅	5.80
50	50∅	10.10
60	60∅	13.80



Klebschlag-Hammer DBP-Nr. 1088 888 und Auslandspatente

1959-3*



1959 - 3 **	280	31.20
-------------	-----	-------



Karosserie- Blechsneider

1960*



mit Ersatzmesser

Bestell-Nr.	mm	Preis
1960	275	21.30
1960 - 1	Ersatzmesser	6.30



Außen-Ausbeulgerät mit 10 Anlötschlaufen und 2 Bolzen

1965*



1965	440	26.—
1965 - 1	Anlötschlaufen	6.— per 10 Stück
1965 - 2	Bolzen	3.40 per 10 Stück



Magnetsucher

1976

400 g Haftfähigkeit
mit Permanent-Magnet,
Transparentheft

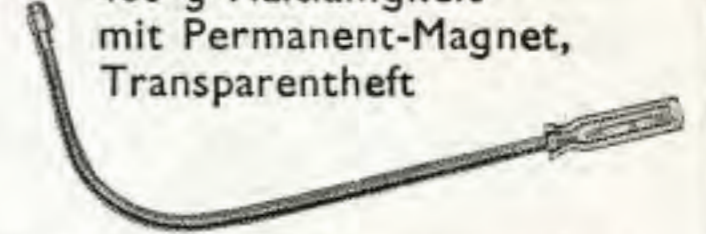

Bestell-Nr.	mm	Preis
1976	520	16.60



Metallsägebogen verstellbar

1980

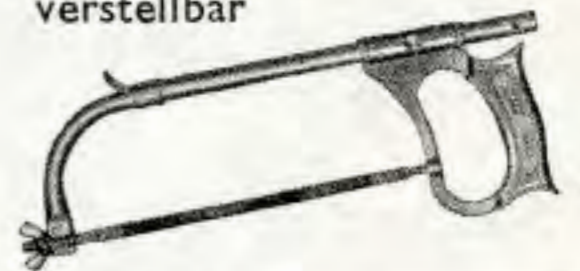

1980	475	11.—
lose Sägeblätter, 2% Wolfram legiert		
1980 B - 1	225 × 16 × 0,8	0.60
2	300 × 16 × 0,8	0.65



Metallsägebogen feststehend

1981

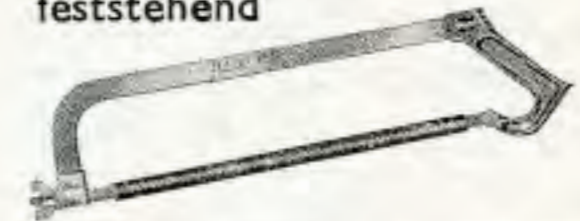

1981	460	7.10
lose Sägeblätter, 2% Wolfram legiert		
1980 B - 2	300 × 16 × 0,8	0.65



Sechskant- Stiftschlüssel

2100



CHROM-VANADIUM

für Inbus-Schrauben

Metr. Maße

Bestell-Nr.	mm/Zoll	Glanzvernickelt
2100 - 02	2	0.68
03	3	0.70
04	4	0.76
05	5	0.86
06	6	1.08
07	7	1.24
08	8	1.36
09	9	1.58
10	10	1.68
12	12	2.10
14	14	2.90
17	17	4.90
19	19	6.40
22	22	8.60

Amerik. Maße

2100A - 05	5/64	0.68
06	3/32	0.70
08	1/8	0.70
10	5/32	0.76
12	3/16	0.86
14	7/32	0.96
16	1/4	1.08
20	5/16	1.36
24	3/8	1.68
32	1/2	2.32
36	9/16	2.90
40	5/8	4.20
48	3/4	6.10

Sätze in Plastic-Taschen
Metr. Maße

Bestell-Nr.	Inhalt	Glanzvernickelt
2100 - 7 P	2 — 8	8.20
2100 - 10 P	2 — 12	17.60
2100 - 14 P	2 — 22	42.90

Amerik. Maße

2100 - 9 AP	5/64 — 3/8	10.80
2100 - 11 AP	5/64 — 9/16	20.30
2100 - 13 AP	5/64 — 3/4	31.60



Sechskant-Stiftschlüssel
CHROM-VANADIUM
Transparentheft

2110



für Inbus-Schrauben

Metr. Maße

Bestell-Nr.	mm/Zoll	Glanzvernickelt
2110 - 02	2	1.20
03	3	1.40
04	4	1.70
05	5	1.90
06	6	2.40
07	7	2.60
08	8	2.80
09	9	3.—
10	10	3.20
12	12	4.30

Amerik. Maße

2110 A - 05	5/64	1.20
06	3/32	1.20
08	1/8	1.40
10	5/32	1.60
12	3/16	1.90
14	7/32	2.—
16	1/4	2.20
20	5/16	2.80
24	3/8	3.20
32	1/2	4.50



Ergänzungswerkzeuge
für Sortimente

2140-2143

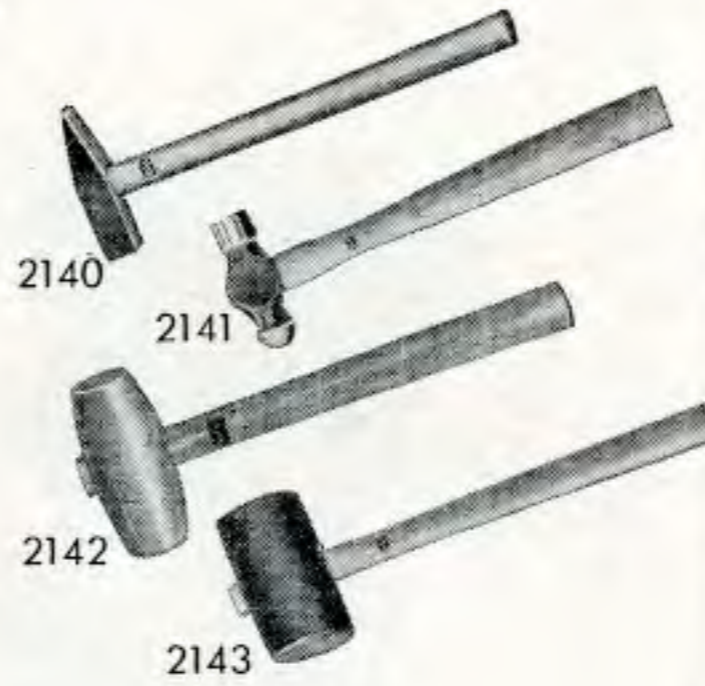

Bestell-Nr.	Bezeichnung	Preis
2140 - 2	Schlosserhammer 200 g	3.30
3	dto. 300 g	4.—
4	dto. 400 g	4.30
5	dto. 500 g	4.90
10	dto. 1000 g	7.80
2141 - 1	Engl. Hammer 3/4 lbs.	4.90
2	dto. 1 lbs.	5.30
4	dto. 2 lbs.	8.80
2142	Leichtmetallhammer 500 g	9.70
2143	Gummihammer 90x50 mm 500 g	6.20



Klein-Rohrabschneider
für Rohre aus Kupfer, Messing
und sonstigen NE-Metallen

2180

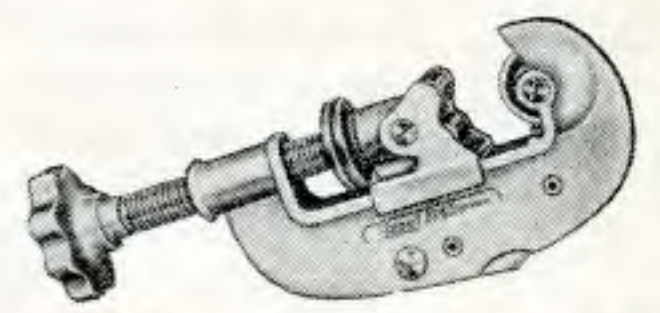

Bestell-Nr.	Bezeichnung	Preis
2180	für Rohre bis 25 mm = 1" Außendurchmesser	24.50
2180 - 1	Ersatzrädchen 20x4,8x5,1 mm	4.10
2180 - 2	Ersatzbolzen für Rädchen	0.40



Bördelgerät

2190

für Bremsleitungen usw., mit auswechselbaren, scharnierten Spannbacken und Vorrichtung zur Oberflächenglättung des Öffnungswinkels

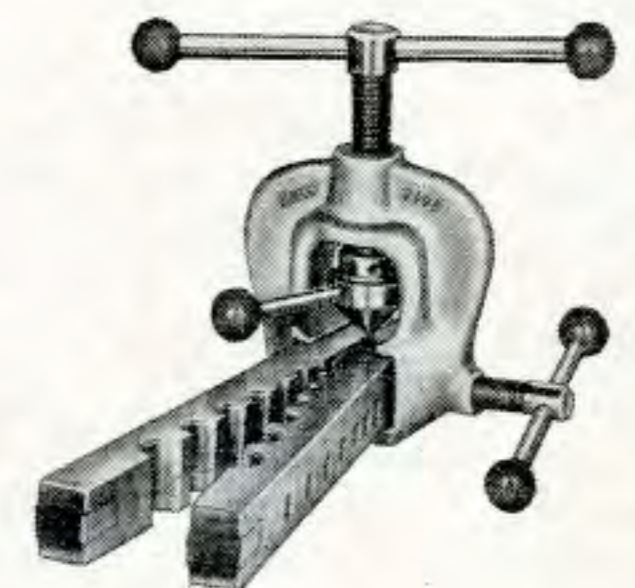

Bestell-Nr.	mit Spannbacken	Preis
2190	mm	42.80
2190 A	Zoll	42.80
Ersatz-Spannbacken		
2190 - 1	4 4,75 6 8 10 12 14	25.60
2190 - 2	3/16 1/4 5/16 3/8 7/16 1/2 5/8 A	25.60



Ergänzungswerkzeuge
für Sortimente

2120-2135

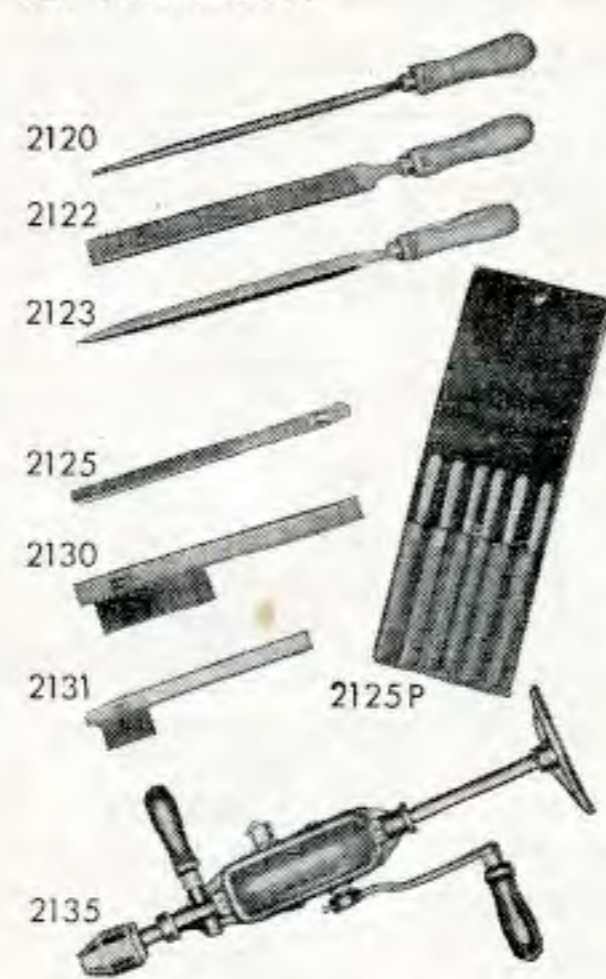

Bestell-Nr.	Bezeichnung	Preis
2120 - 8	Rundfeile 8"	3.40
10	Rundfeile 10"	4.50
2122 - 5	Flachfeile 5"	1.90
8	Flachfeile 8"	3.40
10	Flachfeile 10"	4.60
2123 - 6	Dreikantfeile 6"	2.60
8	Dreikantfeile 8"	3.70
10	Dreikantfeile 10"	4.80
2125	Kontaktfeile	1.10
2125 P	Kontaktfeilen-Satz in Plastic-Tasche	7.20
2130	Drahtbürste	1.30
2131	Zündkerzenbürste	0.80
2135	Handbohrmaschine	42.80



2146-2161



2146	Fühlerblattlehre 5teilig für VW	2.—
2147	dto., 20teilig „Spion“	6.90
2147 A	dto., SAE-Maße	7.70
2150	Reißnadel	3.10
2152	Prüflampe (Schraubenzieher mit Prüflampe u. Anschlußkabel) im Etui	4.20
2154	Rollbandmaß, 2 m	1.80
2156	Kabelmesser	3.90
2160	Ölspritzkanne	8.10
2161	Ölkännchen „Ölboy“ Kännchen für Öl und Caramba	4.80

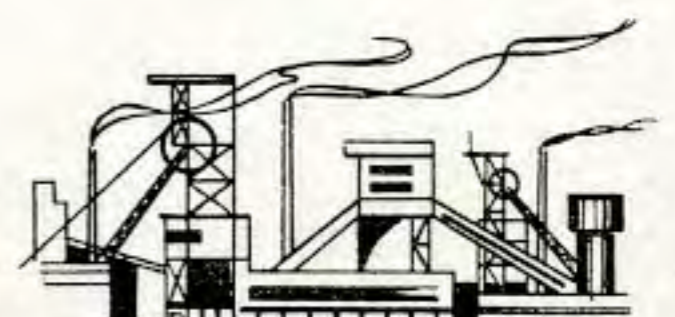
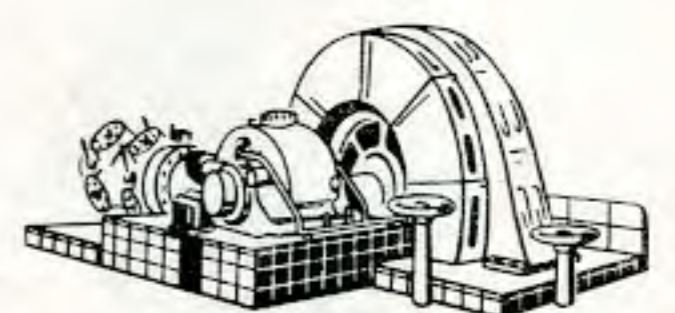



Assistent*

2500 A

Werkzeugwagen
DBP-Nr. 949640
und Auslandspatente
mit Werkzeugsortiment
CHROM-VANADIUM
für Volkswagen



Bestell-Nr.	Inhalt	Preis
5/450- 6x7 22x27	8x10 10x14 12x14	
6/450- 9x11	14x17 17x19	je 2
2/605-13x13	15x15	
1/615-11x13		
4/630- 6x7	8x10 12x14 17x19	
2/650-12	1/731-5 1/745-2	
1/746-2	1/760-3 1/764	
1/811-3	1/811-9 1/813-2	
1/814-2	1/821-1 1/834-3	
6/900-10	11 13 14 15 17	
1/915	1/918 1/921	
1/922	1/1802-2 1/1855-2	
1/2100-08	1/2120-8 1/2122-8	
1/2125	1/2130 1/2140-3	
1/2140-5	1/2143 1/2146	
1/2150	1/2152 2/2161	
1/2509	2/2513-27 1/2527-13	
1/2527-14	1/2559-24 1/2561	
1/2565	1/2567	
2500A/65	65 teilig	534.—
wie vor, jedoch zusätzlich:		
	1/916 1/917 2/2513-32	
2500A/69	69 teilig	564.—
Inhalt wie 2500 K/T		
2500A/61	61 teilig	766.—
2500 AL	Werkzeugwagen, leer	234.—



„Tourist“*

2500 E

DBP-Nr. 851780
und Auslandspatente
Ersatzradkappe
mit Werkzeugsatz
CHROM-VANADIUM
für Volkswagen



2/450- 7x8	10x12	
2/605-13x13	14x14	
1/760-3	1/764	1/772
1/811-9	1/813-2	1/814-02a
1/1850-2	1/2561	
2500 E	12 teilig	Preis auf Anfrage



Werkzeugsatz CHROM-VANADIUM

2500 K*

für Volkswagen



im verschließbaren, hausfarbenen
HAZET-Metallkasten

Bestell-Nr.	Inhalt	Preis
2/605-13x13	15x15	
1/615-11x13		
1/630-17x19		
1/790-1	1/798-1	
8/900-10	11 13 14 15 17 19 30	
1/911	1/915 1/917	
1/918	1/919 1/921	
1/922	1/1015 1/1056	
1/2501	1/2507 1/2509	
1/2511	1/2512 2/2513-27	
2/2513-32	1/2514 1/2519	
1/2520-10	1/2520-20 1/2523-75	
1/2523-77	1/2524 1/2525 K	
1/2527-13	1/2527-14 1/2530 a	
1/2530 b	1/2531 1/2531 a	
1/2533	1/2533 a 1/2559-24	
1/2559-27	1/2560 1/2565	
1/2566	1/2567 1/2570	
1/2572	3/2575 1/2576	
1/2590		
2500 K/61	61 teilig	678.—



Werkzeugsatz CHROM-VANADIUM

2500 T*

für Volkswagen

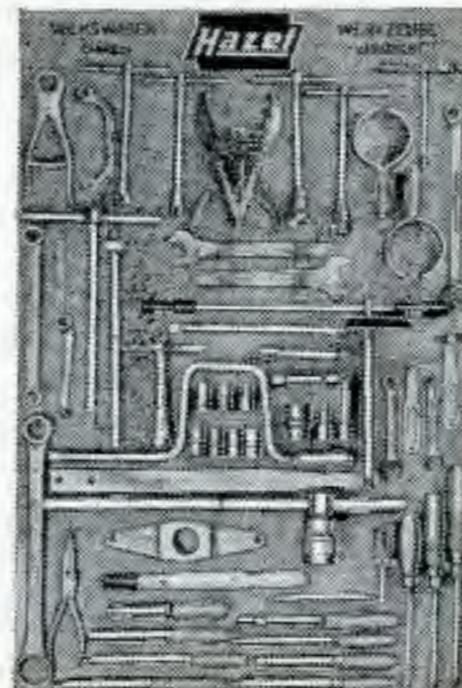

auf hausfarbener
HAZET-Metallwandtafel

Inhalt wie 2500 K/61		
2500 T/61	61 teilig	608.—



Werkzeugsatz CHROM-VANADIUM

2500 P

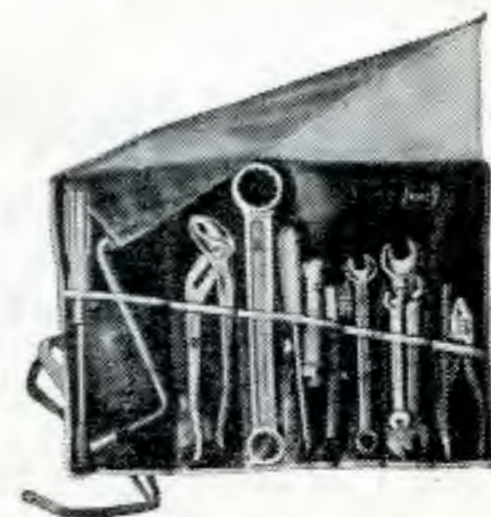
für Volkswagen
in Plastic-Tasche

Bestell-Nr.	Inhalt	Preis
3/450- 8x9	10x14 17x19	
1/600-14x14		
1/760-3	1/764 1/772	
1/811-6	1/813-3 1/1850-2	
1/2125	1/2131 1/2561	
2500 P	13 teilig	63.90



Werkzeugausrüstung CHROM-VANADIUM

2500 WA*

für Volkswagen



im verschließbaren, hausfarbenen
HAZET-Metallkasten

3/450- 8x9	10x14 17x19	
2/605-13x13	15x15	
1/615-11x13		
1/630-17x19		
1/730-3	1/745-2 1/760-3	
1/811-1	1/811-9 1/813-2	
4/900-10	11 14 17	
1/915	1/919 1/921	
1/1801-2	1/1850-3 1/2122-5	
1/2123-6	1/2130 1/2140-5	
1/2142	1/2146 1/2501	
1/2509	2/2513-27 1/2514	
1/2515	1/2527-13 1/2527-14	
1/2559-24	1/2560 1/2562	
1/2562 D	1/2567 1/2572	
3/2575		
2500 WA/45	45 teilig	272.—





Spezialwerkzeuge CHROM-VANADIUM

insbesondere für
Arbeiten an Volkswagen

Bestell-Nr.	mm	Verchromt
-------------	----	-----------

Spezial-Zündkerzenschlüssel

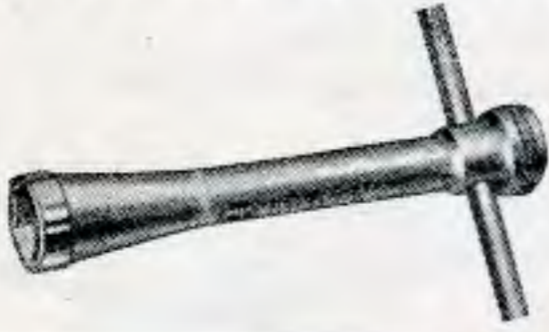

2501	21	8.50
------	----	------

Dorn für Kolbenbolzen



2507		10.10
------	--	-------

Spezial-Ringschlüssel für Ölkühler und Vergaser



2509	10 x 14	8.40
------	---------	------

Werkzeug für Schwungscheibe und Hinterachse

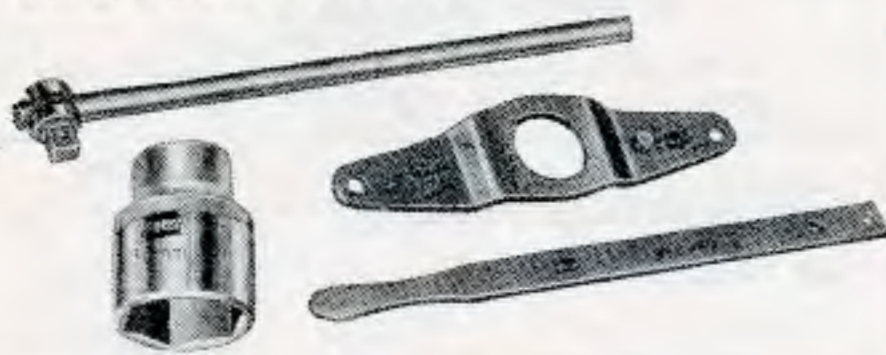

2510	bestehend aus:	
	1015 Schiebegriff 500 mm	17.—
	1056 Einsatz 36 mm	7.80
	2511 Führungsplatte	8.—
	2512 Hebel- verlängerung	7.30

Zwei Gabelschlüssel gerade und gebogen, je 1 Stück



Bestell-Nr.		per Stück
2513 - 27	27 mm, gerade und gebogen	3.70
32	32 mm, gerade und gebogen	4.10

T-Griff-Schlüssel 8 mm Innenvierkant



Bestell-Nr.	mm	Verchromt
2514	8	7.40

Führungsdorn zum Zentrieren der Kupplungsscheibe



2519		10.30
------	--	-------



Spezialwerkzeuge CHROM-VANADIUM

insbesondere für
Arbeiten an Volkswagen

Bestell-Nr.	mm	Verchromt
-------------	----	-----------

Ventileinstell-Lehren mit 10 Reserveblättchen



2520 - 10	0,10	6.80
20**	0,20	6.80

Kolbenring-Spannbänder



Bestell-Nr.	für Kolben	Verchromt
2523 - 75	75 - 76 mm	10.30
77	77 - 78 mm	10.30

Kerbstemmer



2524		3.90
------	--	------

Sprengringzange für Antriebswelle und Kurbelwelle

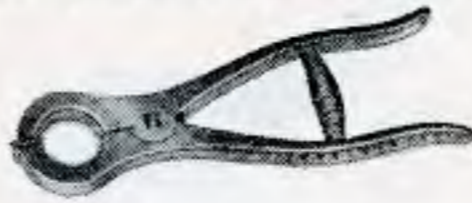

2525 K		28.80
--------	--	-------

Ersatzbacken dazu

2525 K - 1	per Paar	6.20
------------	----------	------

Steckschlüssel mit Kugelgelenk



Bestell-Nr.	mm	Verchromt
2527 - 13**	13	14.40
14	14	14.40

Dorne



Bestell-Nr.	für	Verchromt
2530a	Achsschenkelbolzen 7,9 mm Ø	9.90
2530b	dto., 5,9 mm Ø	9.90
2531	Achsschenkelbolzen- buchsen 17,5 mm Ø	9.90
2531a**	dto., 21,5 mm Ø	9.90
2533	Bundbolzenbuchsen 17,9 mm Ø	10.10
2533a**	dto., 19,9 mm Ø	10.10

Öldruckschalter-Schlüssel mit Kugelgelenk



Bestell-Nr.	mm	Verchromt
2559 - 24**	24	16.80
27	27	16.80



Spezialwerkzeuge CHROM-VANADIUM

insbesondere für
Arbeiten an Volkswagen

Bestell-Nr.	mm	Verchromt
-------------	----	-----------

Spezialringschlüssel



2560	27 x 36	15.30
------	---------	-------

Ventileinschleifer mit Saugnapf



2570	25 mm Ø	2.40
------	---------	------

Spezienschlüssel für Brennstoffhahn



2572		5.30
------	--	------

Kreuzschlitz-Schraubenzieher- satz



2575 - 3	Nr. 814-2,-3,-4	15.10
----------	-----------------	-------

Sprengringzange für Kolbenbolzen



2576		9.60
------	--	------

Ringschlüssel doppelseitig gekröpft



630	17 x 19	4.80
-----	---------	------

Kolbenringzange



790 - 1	50 - 100	8.80
---------	----------	------

Schwungwinde 1/2" □

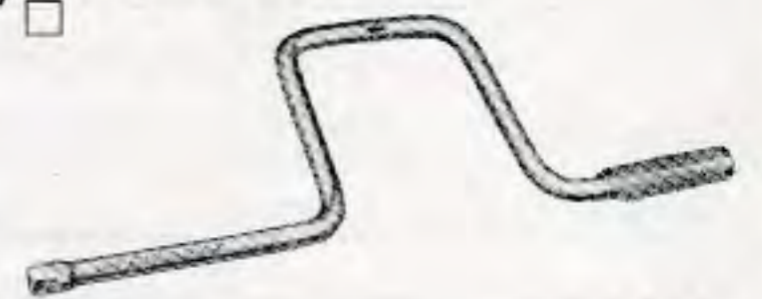

911		7.90
-----	--	------

Schiebegriff 1/2" □



915		6.—
-----	--	-----

Verlängerungen 1/2" □



917	125	3.—
918	250	4.—

T-Griff-Schlüssel 1/2" □

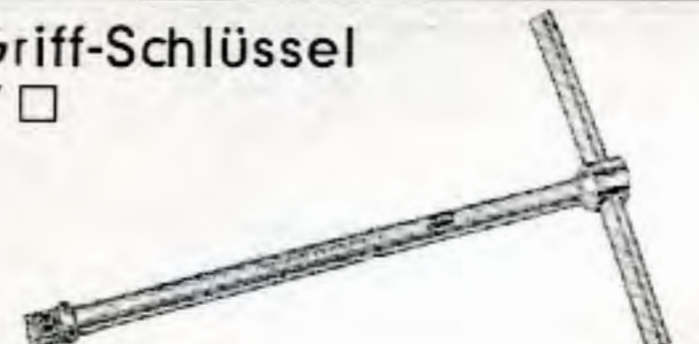

919		8.80
-----	--	------



**Spezialwerkzeuge
CHROM-VANADIUM**

insbesondere für Arbeiten
an Volkswagen

Bestell-Nr.	mm	Verchromt
-------------	----	-----------

Sechskant-Einsätze

1/2" □

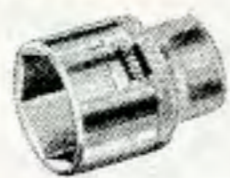

900 - 10	10	2.10
11	11	2.10
13	13	2.10
14	14	2.20
15	15	2.20
17	17	2.70
19	19	2.70
30	30	3.90

INBUS-Einsätze

1/2" □



921	8	4.40
922	10	4.60

Drehmomentschlüssel

bis 6 mkg maximal

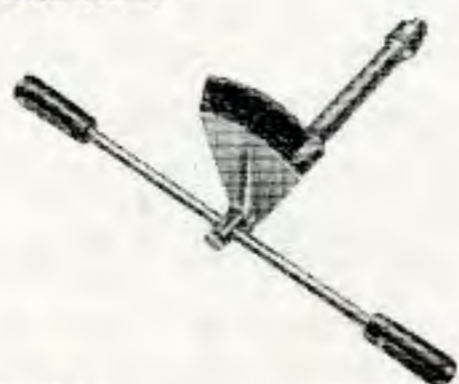

2590		75.50
------	--	-------

Ringschlüssel



2561	21 x 36	10.50
------	---------	-------

Steckschlüssel

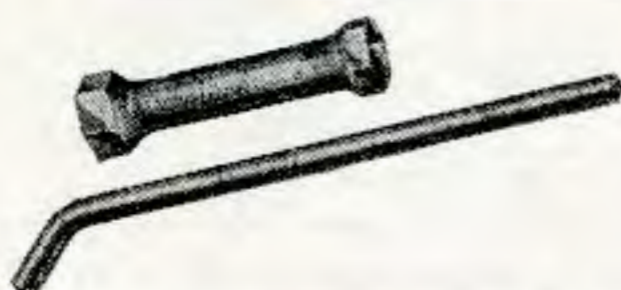

2562	27 x 30	2.90
------	---------	------

Dorn dazu

2562 D	12 mm Ø	1.30
--------	---------	------

**Spezialschlüssel
für Zylinderkopfmuttern**



2565	15	10.50
------	----	-------

**Spezialschlüssel
für Schalter des
Scheibenwischer-Motors**

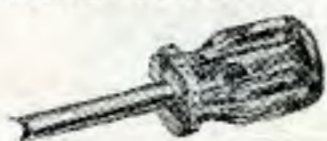

2566		4.20
------	--	------

**Spezialschlüssel
für den Öldienst**



2567 **	17 x 21	10.30
---------	---------	-------



**Spezialwerkzeuge
CHROM-VANADIUM**

insbesondere für Arbeiten
an Mercedes-Fahrzeugen

Bestell-Nr.	mm	Preis
-------------	----	-------

Ventileinstellschlüssel

Maulstellung 0 und 30°



325	14 x 14	3.90
-----	---------	------

Ventileinstellschlüssel

(Geißfuß)



326	vorerst nicht lieferbar	
-----	-------------------------	--

Spezialschlüssel

für Ventileinstellung DBGM
mit Schraubenzieher



327	14	31.40
-----	----	-------

Spezialschlüssel

für Ventileinstellung DBGM
mit Schraubenzieher, speziell für Unimog

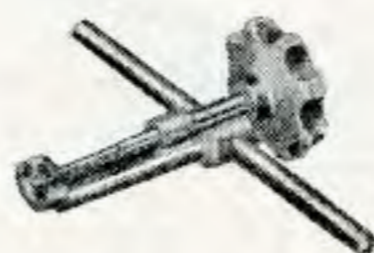

328	14	27.60
-----	----	-------

Gelenk-Zündkerzenschlüssel

mit Gelenkspannfeder



762	21	10.60
-----	----	-------

Gelenk-Zündkerzenschlüssel

mit Kugelgelenk

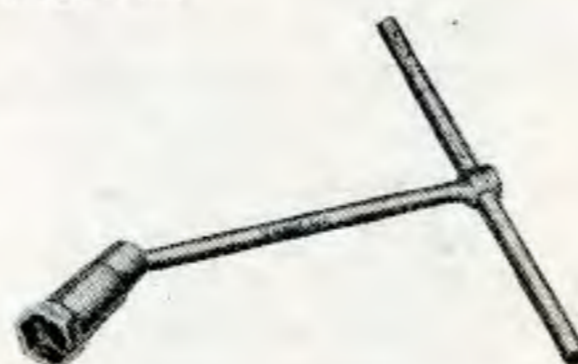

767	21	6.90
-----	----	------

T-Griff-Schlüssel

für INBUS-Schrauben



2715	10	11.20
2716	8	10.10
2717	6	12.—
2718	5	8.20



**Spezialwerkzeuge
CHROM-VANADIUM**

insbesondere für Arbeiten
an Mercedes-Fahrzeugen

Bestell-Nr.	mm	Preis
-------------	----	-------

T-Griff-Schlüssel

für INBUS-Schrauben
Spezialschlüssel für Ölwanne



2719	6	13.10
------	---	-------

**Spezial-Doppelgelenkschlüssel
für Ölwanne**

3/8" □



2722	6	27.10
------	---	-------

Spezialschlüssel

für obere Getriebeschrauben und Anlasser



2723	17	13.40
------	----	-------

Gelenkschlüssel

für Federbolzen



2724		12.30
------	--	-------

Kurzgelenkschlüssel

für Ölwanne

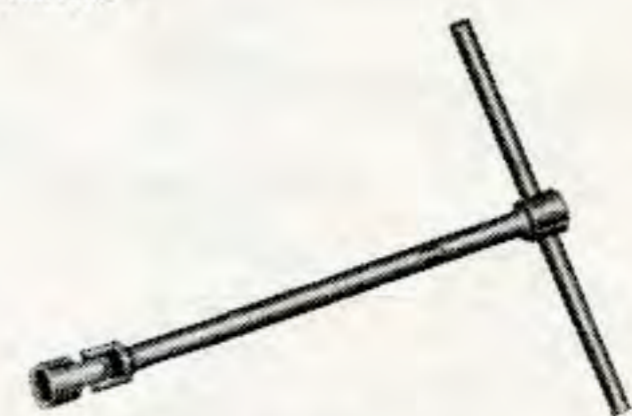

2725	14	19.20
------	----	-------

**Spezialschlüssel
für Lenkrad-Schaltung**

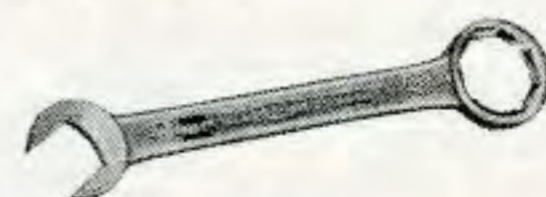

2727	19 x 27	6.70
------	---------	------

**Sechskant-Stiftschlüssel
(INBUS-Schlüssel) nach DIN 911**



2729	14	2.90
------	----	------



Spezialwerkzeuge CHROM-VANADIUM

insbesondere für Arbeiten
an Mercedes-Fahrzeugen

Bestell-Nr.	mm	Preis
INBUS-Schlüssel 1/2" □		
2730	8	6.70
2731	10	7.—
Spezial-Gelenkschlüssel für INBUS-Schrauben 3/8" □		
2739	5	14.90
2740	6	15.60
Kurz-Gelenkschlüssel mit Zwölfkant 3/8" □		
2742	14	22.40
Spezienschlüssel für Register-Vergaser 3/8" □		
2743	12	12.70
Spezienschlüssel für Einspritzleitung 3/8" □		
2745	17	13.30
INBUS-Schlüssel 3/8" □		
2747	5	6.30
2748	6	6.70
2749	8	6.20
2750	10	6.70
Spezienschlüssel für den Öldienst		
2760 **	14 x 17	9.50



Spezialwerkzeuge CHROM-VANADIUM

insbesondere für Arbeiten
an Mercedes-Fahrzeugen

Bestell-Nr.	mm	Preis
Stecker für verschiedene Betätigungswerkzeuge		
8813	∅ 8	1.60
Schiebegriff 3/8" □		
8815		5.20
Kardangelen 3/8" □		
8820		7.30
Verlängerungen 3/8" □		
8821 - 3	3"	4.—
6	6"	4.40
8	8"	5.10
Zwölfkant-Einsätze extra tief 3/8" □		
880 TZ - 14	14	3.60
17	17	4.20
19	19	4.50
Reduzier-Einsatz		
958 R II	3/8 x 1/2"	4.10

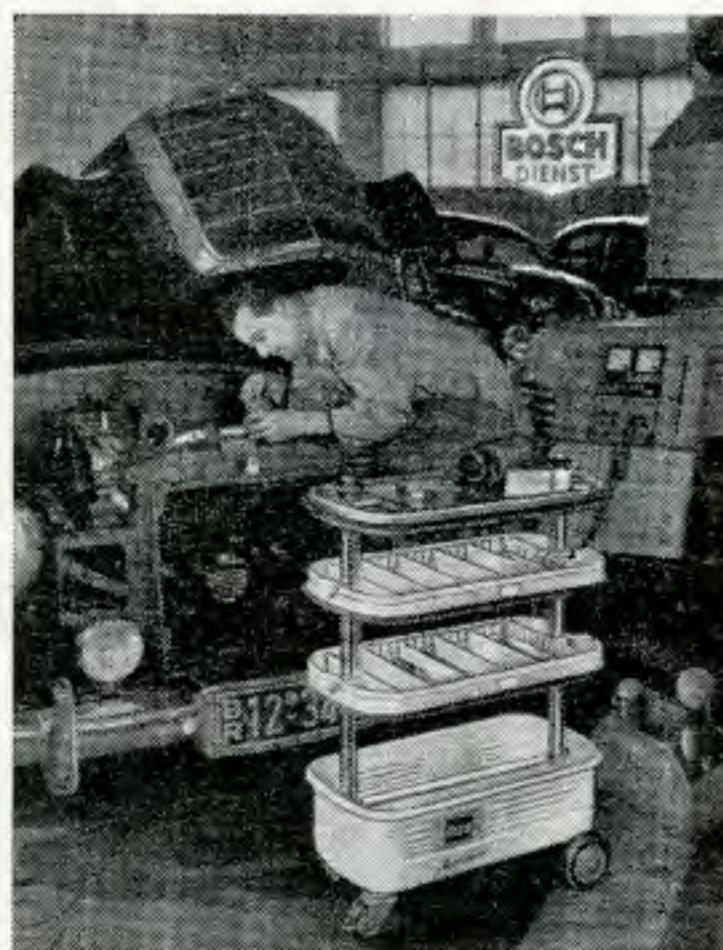

Spezialwerkzeuge CHROM-VANADIUM

insbesondere für Arbeiten
an Mercedes-Fahrzeugen

Sortimente

Bestell-Nr.	Inhalt	Verchromt
Ratschen-Garnitur 3/8" □		
		
im hausfarbenen HAZET-Metallkasten		
2800	17teilig	85.50
Monteur-Satz 3/8" □ in Plastic-Tasche		
		
2804	15teilig	90.80
Monteur-Satz 3/8" □ in Plastic-Tasche		
		
2805	20teilig	188.—
Zwergsatz für Vergaser, Radio usw. 1/4" □ in Plastic-Tasche		
		
2806	35teilig	114.50
An- und Abnehmersatz in Spaltleder-Tasche		
		
2807	12teilig	51.20



**Spezialwerkzeuge
CHROM-VANADIUM**

insbesondere für Arbeiten
an BMW-Fahrzeugen

Sortimente

Bestell-Nr.	Inhalt	Preis
2900	Bordwerkzeugsatz für Pkw, 7 teilig, verchromte Werkzeuge in Plastic-Tasche	
		
2900	3/450- 8x10, 14x17, 19x22 1/760-3 1/2911 1/2920 1/2921	31.10

2902	Bordwerkzeugsatz für Pkw, 11 teilig, verchromte Werkzeuge, lose (ohne Plastic-Tasche)	
2902	5/450-7x9, 8x10, 11x12, 14x17, 19x22 1/760-3 1/2910 1/2911 1/2920 1/2921 1/2923	39.60



**Spezialwerkzeuge
CHROM-VANADIUM**

insbesondere für Arbeiten
an BMW-Fahrzeugen

Einzelwerkzeuge

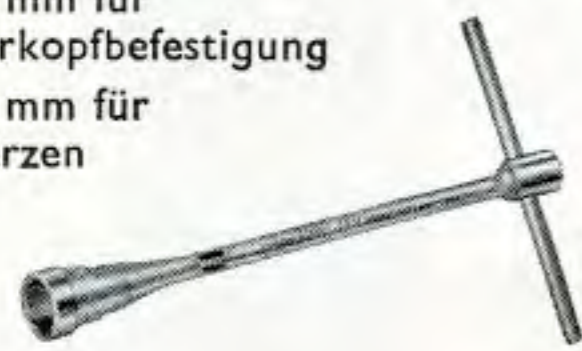





Bestell-Nr.	mm	Preis
Ringschlüssel Maß 14 mm gekröpft Maß 17 mm gerade		
		
2910	14 x 17	3.90
Zündkerzenschlüssel, komb. Maß 14 mm für Zylinderkopfbefestigung Maß 21 mm für Zündkerzen		
		
2911	14 und 21	7.10



**Spezialwerkzeuge
CHROM-VANADIUM**

insbesondere für Arbeiten
an BMW-Fahrzeugen

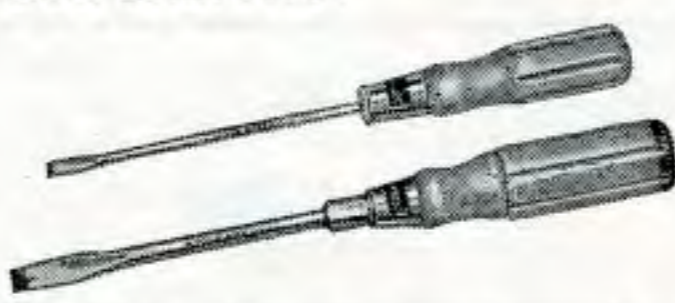
Einzelwerkzeuge

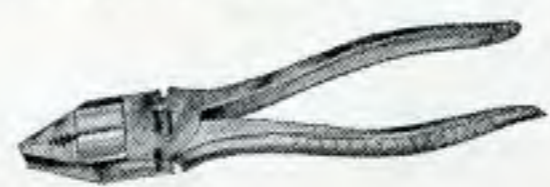
Bestell-Nr.	mm	Preis
Kurbel für Wagenheber und Radmutter mit Radkappenabzieher		
		
2912		8.40
Schlüssel für Ringmuttern		
		
2913		4.50
Schlüssel für Steuerkopf		
		
2914		3.40
Gabelschlüssel für Motorrad		
		
2915	8 x 10	1.40
2916	9 x 11	1.50
2917	12 x 14	1.60
2918	14 x 17	1.90
2919	19 x 22	2.20
Schraubenzieher		
		
2920	100 x 4	2.50
2921	125 x 7	3.50
Ringschlüssel für Motorrad		
		
2922	12x14, gerade	2.40
2922a	12x14, gebogen	2.50
Kombinationszange		
		
2923	6"	6.20



**Spezialwerkzeuge
CHROM-VANADIUM**

insbesondere für Arbeiten
an BMW-Fahrzeugen

Einzelwerkzeuge

Bestell-Nr.	mm	Preis
Maulschlüssel flach gestanz, für Motorrad		
		
2924	36 x 41	3.30
Gabel-Ringschlüssel flach gestanz, für Motorrad		
		
2925	17 x 27	2.40
Kombinationsschlüssel für BMW 600 (Radmutter- und Zündkerzenschlüssel, Radkappenabheber)		
		
2932		5.80
Gabelschlüssel		
		
450 - 0079	7 x 9	1.70
0810	8 x 10	1.70
1112	11 x 12	1.80
1417	14 x 17	2.50
1922	19 x 22	2.70
Universalzange		
		
760 - 3	9 1/2"	6.-
DIN 895	Gabelschlüssel SPEZIALSTAHL	
		
895	vorerst nicht lieferbar	

Bestell-Nr.	Bezeichnung	DM	Bestell-Nr.	Bezeichnung	DM
619	Spezial-Schraubenschlüssel für den Öldienst an Opel-Wagen 22 mm: für Getriebeablaßschraube 32 mm: für Differential-Stopfen 41 mm: für Ölwanne	9.30	2520-20	SPEZIALWERKZEUGE FÜR VOLKSWAGEN Ventileinstell-Lehre 0,20 mm mit 10 Reserveblättchen	6.80
705 V	Kreuzschlüssel verchromt (Ersatz für 715) 705 V = 17 × 19 × 20,64 × 22 705 AV = 5/8 × 3/4 × 13/16 × 7/8	10.50	2527-13	Steckschlüssel mit Kugelgelenk, 13 mm	14.40
760 N	Universalzange 9 1/2" mit 5 Führungsrillen	12.40	2531 a	Dorn für Achsschenkelbolzen und -buchsen, Zapfendurchmesser 21,5 mm	9.90
			2533 a	Dorn für Bundbolzenbuchsen, Zapfendurchmesser 19,9 mm	10.10
768-17	Radmutternschlüssel für Pkw, 17 mm	8.40	2559-24	Öldruckschalter-Schlüssel mit Kugelgelenk, 24 mm	16.80
798	Schlauchklemmzangen mit Sperrvorrichtung 798 - 1 = 280 mm (11") 798 - 2 = 415 mm (16 1/2")	13.40 14.80	2567	Spezial-Schraubenschlüssel für den Öldienst 17 mm Inbus: für Ölablaß- und Öleinfüllschraube am Getriebe sowie Untersetzungsgetriebe am VW-Transporter 21 mm Ringschlüssel: für Ölablaßschraube am Motor und für die Keilriemenscheibe	10.30
863 E	Komplettes Einsatzteil, für Umschaltknarre 863 mit Drehknopf und Federring	9.80			
916 NE	Komplettes Einsatzteil, für Umschaltknarre 916 N mit Drehknopf und Federring	17.90	2760	SPEZIALWERKZEUG FÜR MERCEDES-WAGEN Spezial-Schraubenschlüssel für den Öldienst 14 mm Inbus: Ölablaßschrauben und Kontroll-Stopfen an Getriebe und Hinterachse 17 mm Ringschlüssel: Ölablaßschrauben am Motor	9.50
1959-3	Klebschlag-Hammer 280 mm (11") lang DBP-Nr. 1 088 888 und Auslandspatente mit dauerplastischer Füllmasse für materialschonende Schläge	31.20			



INHALTSVERZEICHNIS

	Seite		Seite		Seite
A	Abzieher	13	K	Kabelmesser	25
	Assistent	3, 26		Kardangelenke	16, 18, 20, 21
	Aufsatzschrank	3		Karosserie-Blechsneider	24
	Aufsteckknarre	18		Karosserie-Werkzeuge	23, 24
	Aufsteckrohre für Ringschlüssel	11		Klebschlag-Hammer	24
	Ausbeulwerkzeuge	23-24		Kleingabelschlüssel	4, 5
B	Batterie-Werkzeuge	14, 23		Klein-Rohrschneider	25
	Betätigungswerkzeuge für Einsatzkästen	16, 18, 20, 21		Knarrenschlüssel	16, 18, 20, 21
	Bleischere	23		Körner	12
	Blockschlüssel	9		Kolbenringspannbänder	14, 27
	BMW-Spezialwerkzeuge	30		Kolbenringzangen	14, 27
	Bördelgerät	25		Kombinationszangen	23
	Bremsfederzangen	14		Kraftseitenschneider	22
D	Dekorations- und Verkaufstafeln, Ständer 4, 5, 7, 9, 10, 11, 12, 23, 26		L	Lagerschaber	15
	Doppelmaulschlüssel	4-7, 30		Langbeckzangen	22
	Drahtbürste	25		Leichtmetallhammer	25
	Drehmomentschlüssel	28		Lenkradabzieher	13
	Drehstifte	5		Löffelschaber	15
	Dreikantschaber	15		Long-Grip-Zangen	22
	Durchschläger	12	M	Magnetsucher	24
E	Einsätze	16-21		Maulschlüssel	4-7, 27, 30
	Einsatzkästen	16-21		Meißel	12
	Einschleifer für Ventile	14		Mercedes-Spezialwerkzeuge	28, 29
	Elektriker-Schraubenzieher	15		Metallsägebogen	24
	Englische Hämmer	25		Monteursätze (Volkswagen-, Mercedes- und BMW- Spezialwerkzeuge)	26, 29, 30
	Ersatzrad-Kappe mit Werkzeug für VW	26		Montiereisen	11
F	Feilen	25		Motorradfahrer-Werkzeugsatz	14
	Figureschere	23	O	Oldienstschlüssel	9, 28, 29
	Flachmeißel	12		Oldruckschalterschlüssel	27
	Flachzangen	22		Ölkännchen	25
	Fordson-Traktorentasche	21	P	Plastic-Hämmer	24
	Fühlerblattlehren	25		Polklemmenabzieher	14
G	Gabelschlüssel	4-7, 27, 30		Polklemmenreinigungsbürste	14
	Gabel-Ringschlüssel	7-8		Polklemmenzange	14
	Gegenstützvorrichtung	13		Popular-Kreuzschlüssel	11
	Gelenkschlüssel	11		Prüflampe	25
	Grip-Zangen	12	R	Radabzieher	13
	Gummihämmer	24, 25		Radmutternschlüssel	13
H	Hämmer	24, 25		Radschraubenkurbel	13
	Handbohrmaschine	25		Reduziereinsätze	16, 20, 21
	HAZET-Assistent	3, 26		Reifenheber	11
	Herrenfahrer- Werkzeugtaschen	14, 26, 30		Reißnadel	25
	Hohlschaber	15		Reklameständer und Reklametafeln 4, 5, 7, 9, 10, 11, 12, 23, 26	
I	Inbuseinsätze	18, 20		Ringschlüssel	8-11
	Innenauszieher	13		Rohrschneider	25
	Innensechskant-Stiftschlüssel	24, 25		Rollbandmaß	25
	Isolierte Hämmer	24		Rollgabelschlüssel	4
	Isolierte Schraubenzieher	15, 16		Rundzangen	22
	Isolierte Zangen	12, 22, 23	S	Sägebogen	24
				Säureprüfer	14
				Sechskant-Einsätze	16, 17, 19, 21
				Sechskant-Einsatzkästen	16-20
				Sechskant-Steckschlüssel	5
				Sechskant-Stiftschlüssel	24, 25
				Seitenschneider	22
				Spannbänder für Kolbenringe	14, 27
				Spezialschlüssel für Oldienst	9, 28, 29
				Spezialwerkzeuge für BMW-Wagen	30
				Spezialwerkzeuge für Mercedes-Wagen	28, 29
				Spezialwerkzeuge für Volkswagen	26-28
				Spezialzangen für Seegersicherungen	23
				Splintenausziehzeuge	22
				Splintentreiber	12
Sch	Schaber	15			
	Schlauchklemmenzange	14			
	Schlosserhammer	25			
	Schnellspann-Universalzange	12			
	Schränke (verschiedene Ausführungen)	3			
	Schraubenausdreher	16			
	Schraubenzieher	15, 16			
	Schweißer-Grip-Zange	12			
	Schwere Ringschlüssel	11	St	Starter- und Blockschlüssel	9
				Steckschlüssel	5
				Steckschlüssel-Einsätze	16-21
				Steckschlüssel-Einsatzkästen	16-21
				Stehbolzenauszieher	16
				Steuerradabzieher	13
				Stiftschlüssel für Innensechskant	24, 25
T	Taschen für Herrenfahrer	14, 26, 30			
	Tasche für Motorradfahrer	14			
	Taschen für Volkswagen-, Mercedes- und BMW-Werkzeugsätze	26, 29, 30			
	Traktorensätze	21	U	Umschaltknarren	16, 18, 20, 21
				Universal-Figureschere	23
				Universal-Grip-Zangen	12
				Universal-Radabzieher	13
				Universal-Zangen	12
V	Ventileinschleifer	14			
	Ventileinstellschlüssel	4			
	Ventileinstellschraubenzieher	4, 16, 28			
	Ventilfederhebezange	14			
	Ventilfederspannapparat	14			
	Ventilkeilpistole	14			
	Verkaufsstände und Verkaufs- tafeln 4, 5, 7, 9, 10, 11, 12, 23, 26				
	Verstellbare Schlüssel	4			
	Volkswagen-Ersatzradkappe mit Werkzeug	26			
	Volkswagen-Spezialwerkzeuge	26-28			
	Volkswagen-Werkzeugwagen, -Kästen, -Tafeln und -Taschen	26			
	Vorschneider	22	W	Wasserpumpenzangen	12
				Werbe- und Verkaufstafeln, Ständer 4, 5, 7, 9, 10, 11, 12, 23, 26	
				Werkbank	3
				Werkzeug-Ausrüstungen	14, 21, 26
				Werkzeug-Kästen	3, 14, 21, 26
				Werkzeug-Koffer	3
				Werkzeugsätze	14, 15, 21, 26, 29, 30
				Werkzeug-Schränke	3
				Werkzeugwagen HAZET-Assistent	3, 26
				Winkelschraubenzieher	15
Z	Zangen	12, 14, 22, 23			
	Zellenprüfer	14			
	Zündkerzenbürste	25			
	Zündkerzenprüfer	16			
	Zündkerzenschlüssel	12, 13			
	Zwölfkant-Einsätze	17-19, 21			
	Zwölfkant-Einsatzkästen	17-20			
	Zwölfkant-Gelenkschlüssel	11			

* = Sonderprospekte anfordern

** = Ergänzungen seit dem Katalog 1958 P (siehe Seite 31).

Gestrichen: HAZET 1120, 2500 MT, 2720, 2733, 2734, 2754 und 2755.

Weiterhin sind einige nicht gängige Sätze bei den Gabelschlüsseln, Steckschlüsseln, Ringschlüsseln und Werkzeugtaschen gestrichen worden, die jedoch auf Wunsch nach wie vor geliefert werden können.

Hazet

